

ABSTRACT

Title of Document:

A SYSTEMS ENGINEERING
FRAMEWORK FOR METABOLIC
ENGINEERING EXPERIMENTS

Joseph Johnnie, Master of Science in Systems
Engineering, 2011

Directed By:

Dr. Mark Austin, Department of Civil and
Environmental Engineering, and the Institute
for Systems Research, University of Maryland
at College Park

Cells of living organisms simultaneously operate hundreds or thousands of interconnected chemical reactions. Metabolic networks include these chemical reactions and compounds participating in them. Metabolic engineering is a science centered on the analysis and purposeful modification of an organism's metabolic network toward a beneficial purpose, such as production of fuel or medicinal compounds in microorganisms. Unfortunately, there are problems with the design and visualization of modified metabolic networks due to lack of standardized and fully developed visual modeling languages. The purposes of this paper are to propose a multilevel framework for the synthesis, analysis and design of metabolic systems, and then explore the extent to which abstractions from systems engineering (e.g., SysML) can complement and add value to the abstractions currently under development within the greater biological community (e.g., SBGN). The computational test-bed that accompanies this work is production of the anti-malarial drug artemisinin in genetically engineered *Saccharomyces cerevisiae* (yeast).

A SYSTEMS ENGINEERING FRAMEWORK FOR METABOLIC ENGINEERING
EXPERIMENTS

By

Joseph Johnnie

Thesis submitted to the Faculty of the Graduate School of the
University of Maryland, College Park, in partial fulfillment
of the requirements for the degree of
Master of Science
2011

Advisory Committee:
Dr. Mark Austin, Chair
Dr. Ganesh Sriram, Committee Member
Dr. Ray Adomaitis, Committee Member

UMI Number: 1506642

All rights reserved

INFORMATION TO ALL USERS

The quality of this reproduction is dependent on the quality of the copy submitted.

In the unlikely event that the author did not send a complete manuscript and there are missing pages, these will be noted. Also, if material had to be removed, a note will indicate the deletion.



UMI 1506642

Copyright 2012 by ProQuest LLC.

All rights reserved. This edition of the work is protected against unauthorized copying under Title 17, United States Code.



ProQuest LLC.
789 East Eisenhower Parkway
P.O. Box 1346
Ann Arbor, MI 48106 - 1346

© Copyright by
Joseph Johnnie
2011

Dedication

This paper is dedicated to my parents, Elizabeth Johnnie and Johnnie Nedungattu.

Without their steadfast support, I would not be where I am today.

Acknowledgements

I would like to acknowledge the following people, all of whom have contributed to this work. Dr. Mark Austin (Department of Civil and Environmental Engineering and Institute of Systems Research), in his role as thesis advisor, helped me to define the overall scope and direction of my research. He has provided me technical advice with respect to understanding metabolic engineering from a systems perspective, and editorial input on my research papers as well. Assistant Professor Ganesh Sriram (Department of Biomolecular and Chemical Engineering) has helped guide me through the metabolic research for this paper. He has been instrumental in introducing and bringing me up to speed in the metabolic engineering space to the point where I could successfully integrate metabolic engineering with systems engineering. Professor Raymond Adomaitis brought a unique perspective as a professor with dual faculty appointments in the departments of Biomolecular and Chemical Engineering and the Institute for Systems Research. Since this research aims to integrate research from these two fields, his input was invaluable.

Dr. Austin, Dr. Sriram, and Dr. Adomaitis all served as members of the thesis committee with Dr. Austin functioning as chair.

Dr. Ashish Misra and Mr. Matt Conway, members of Dr. Sriram's lab, were also implementing Flux Balance Analysis for their own individual projects during the summer of 2011. Rather than pursue these efforts separately, we decided to unite our efforts as a group. This resulted in a lot of positive momentum which we each carried forward into our own individual research. I am grateful to them for their help and assistance with the metabolic engineering component of my research.

Mrs. Susan Frazier, the Institute of Systems Research Director of Human Resources and Education, was instrumental in encouraging me to pursue the research based master's degree in systems engineering and guiding me through the application process. Without her help, I would have never had the opportunity to complete this project.

I would also like to thank the Institute of Systems Research community as a whole, along with the members of the Sriram Metabolic Engineering Laboratory. Both groups fostered a tremendously supportive environment in which to pursue research.

Table of Contents

Dedication.....	ii
Acknowledgements.....	iii
Table of Contents.....	v
List of Tables.....	vii
List of Figures.....	viii
Chapter 1 Introduction.....	1
1.1 - Problem Statement.....	1
1.2 – Scope and Objectives.....	5
Chapter 2 – Multi-Level Framework for Orchestration of Good Design Solutions.....	7
2.1 – Approach.....	7
2.1.1 - Strategies for Dealing with Increases in System Complexity.....	7
2.1.2 - Solution Mechanisms.....	10
2.1.3 - Multi-Level Framework for Metabolic Process Design.....	13
2.1.4 - Systems Integration.....	15
2.2 – Semi-Formal Models for Metabolic Engineering.....	16
2.2.1- Goals and Scenarios.....	16
2.2.2 – Abstraction: Ad Hoc Metabolic Engineering Diagrams.....	17
2.2.3 - Abstractions: SBGN.....	18
2.2.4 - Abstractions: SysML.....	23
2.3 - Formal Models for Metabolic Engineering.....	27
2.3.1 - Flux Balance Analysis.....	27
2.3.2 - OPTKNOCK Algorithm.....	32
2.4 - Formal Model Interface Design for Systems Integration.....	36
Chapter 3 – Metabolic Engineering Experiment.....	38
3.1 – Background.....	38
3.1.1 – Semi-formal Model Design - Goals.....	38
3.1.2- Motivation and History.....	38
3.1.3 – Advance 1: CYP71AV1/CPR Pathway.....	39
3.1.4 – Advance 2: DBR2 Pathway.....	41
3.2 - Formal Models for Metabolic Engineering.....	43
3.2.1 - Tools.....	43

3.2.2 - Methodology.....	44
3.2.3 - Preparing the Model	46
3.2.4 - Setting Parameters and Constraints	51
3.2.5 - OPTKNOCK Results and FBA Verification	53
3.3 – Semi-Formal Models for Metabolic Engineering	57
3.3.1 - Ad Hoc Abstraction	58
3.3.2 - SBGN Abstraction	61
3.3.3 - SysML Abstraction.....	63
3.4 - Systems Integration for Metabolic Engineering	65
Chapter 4 – Conclusion.....	69
4.1 - Summary.....	69
4.2 - Future Work.....	70
Appendices.....	72
Appendix A – MATLAB code	72
References.....	78

List of Tables

Table 1 - Features and problems of ad hoc graphical notations (<i>Novere et al, 2009</i>)	19
Table 2 - Comparison between the three languages of SBGN (<i>Novere et al, 2009</i>)	21
Table 3 - Preparing the Yeast model – Strain 1	49
Table 4 - Preparing the Yeast model - Strain 2	51
Table 5 - Preparing the Yeast Model - Strain 3	51
Table 6 - List of Target Reactions	53
Table 7 - OPTKNOCK Results and Verification (Units: $\mu\text{mol}\cdot\text{gDW}^{-1}\cdot\text{h}^{-1}$).....	53

List of Figures

Figure 1 - Complete Yeast Metabolism (<i>Schellenberger et al, 2010</i>); Highlighted areas represent pathways of high metabolic traffic	2
Figure 2 – Sources of complexity from a biological systems viewpoint	9
Figure 3 - Sources of complexity from a metabolic systems design viewpoint	9
Figure 4 - Increases in programmer productivity over time (Austin 2011)	9
Figure 5 - A Multi-level framework for synthesis, analysis, design and integration of models in metabolic system design	14
Figure 6 - Framework for integration of semi-formal models with formal models.....	16
Figure 7 - Metabolic Engineering Diagrams (Yang et al, 2011; Boyle et al, 2011).....	17
Figure 8 - SBGN examples: (a) process diagram, (b) entity relationship diagram, (c) SBGN activity flow diagram (<i>Novere et al, 2009</i>)	20
Figure 9 - SBGN Process diagram for Glycolysis	22
Figure 10 - Glyphs for SBGN Process Diagrams	22
Figure 11 - SysML Taxonomy (OMG: SysML v 1.2, 2010).....	24
Figure 12 - Internal Block Diagram of a Distiller (<i>Friedenthal et al, 2009</i>)	25
Figure 13 - Parametric Diagram of a Distiller (<i>Friedenthal et al, 2009</i>).....	26
Figure 14- How to translate a reaction network into a linear algebra expression with stoichiometric matrix and flux vector. (<i>Athanasidou et al, 2003</i>)	28
Figure 15 - Applying Steady State and solving for fluxes using linear algebra (<i>Athanasidou et al, 2003</i>)	29
Figure 16 - Flux balance analysis (<i>Orth et al, 2010</i>)	30
Figure 17 - If a linear program has a non-empty, bounded feasible region, the optimal solution will always be one of the corner points (<i>Arsham 2011</i>)	31
Figure 18 - Flux Balance Analysis - Overall Approach (<i>Orth et al, 2010</i>)	32
Figure 19 - OPTKNOCK algorithm framework (<i>Burgard et al, 2003</i>).....	33
Figure 20 - Bilevel programming framework - maximizing cellular and bioengineering objectives (<i>Burgard et al, 2003</i>)	34
Figure 21 – Venn Diagram showing common and distinct features of SysML and SBGN, together with a framework for wrapping formal models with SysML interface constructs (e.g., ports)	36
Figure 22 - Schematic Representation of engineered artemisinic acid biosynthetic pathway in <i>S. cerevisiae</i> (<i>Ro et al, 2006</i>).....	40
Figure 23 - Covello Group Pathway (Source: Zhang et al, 2008)	42
Figure 24 - Schematic of a Computational Metabolic Engineering Experiment.....	45
Figure 25 - A Bar Graph Comparing Pre and Post Knockout fluxes for each strain.....	54
Figure 26 - Lysine Metabolic Pathway	56
Figure 27 –A Non standard de facto Visual Abstraction generated using BIGG and the COBRA Toolbox (<i>Hyduke et al, 2011</i>).....	59

Figure 28 – SBGN compliant notation, generated using VANTED and SBGN-ED software (<i>Junker et al, 2006; Czauderna et al, 2010</i>)..	60
Figure 29 - SysML Visual Model for Pathways of Interest The target pathway for flux is highlighted and the suggested knockouts are crossed out.	62
Figure 30 - Parametric Diagram defining parameters and constraints between MICITD and HACNH reactions	63
Figure 31 - Systems Integration - Plugging the <i>in silico</i> metabolic engineering experiment into the Systems Engineering framework	67

Chapter 1 Introduction

1.1 - Problem Statement

Throughout the systems engineering community, a well-known tenet is that good designs balance the need for functionality and performance against limitations on cost. During the pre-implementation stages of system development (i.e., where a detailed system description may not exist), systems engineers are concerned primarily with system functionality and the identification of key environmental conditions within which this functionality must occur. Models of functionality need to describe what the system will do, and the order in which these functions will be executed, under both normal and abnormal operating conditions. The answers to these basic concerns are commonly expressed as functional requirements. Performance requirements describe how well a system should perform these functions. Interface requirements describe conditions that will allow for communication between subsystems, and, between subsystems and the external environment. Then, as the system development proceeds, engineers assume that it will be possible to control the complexity of developments through separation of design concerns (e.g., function before implementation; logic and physical representations) and decomposition of design solutions into hierarchies. Together these strategies of development lead to loosely coupled system architectures and well-defined hierarchies of behavior which, in turn, can facilitate the definition of simulation models (or corresponding experimental test-beds) and procedures for efficient search of the design space for solutions that are feasible (i.e., satisfy all constraints) and provide a desirable tradeoff in design criteria.

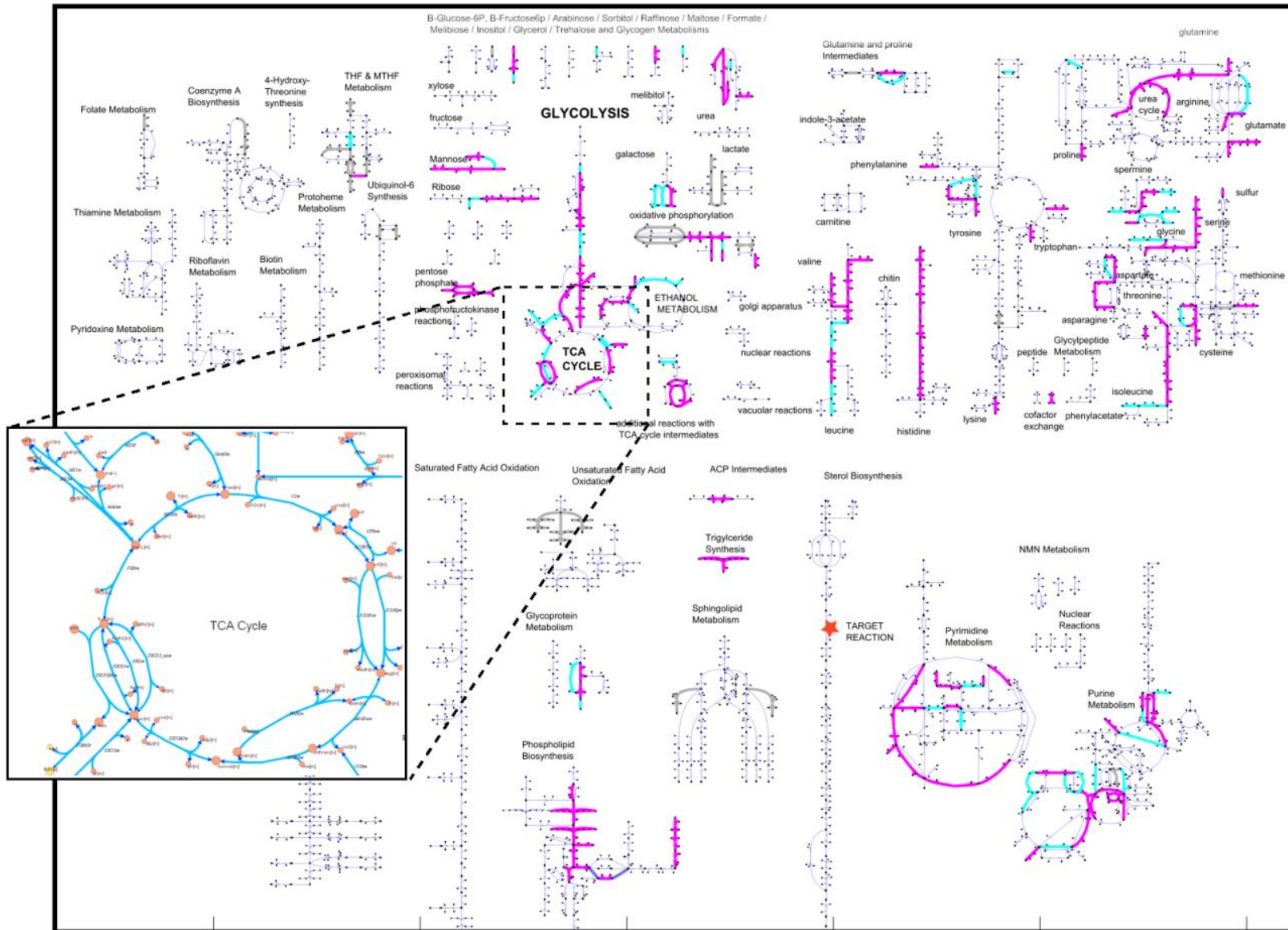

Figure 1 - Complete Yeast Metabolism (Schellenberger et al, 2010); Highlighted areas represent pathways of high metabolic traffic

These principles apply to a wide range of established and emerging application areas. As a case in point, metabolic networks are immensely complex systems characterized by large numbers of nodes (chemical compounds, hereafter referred to as metabolites), and interconnections (reactions). The metabolism of a single microorganism such as *Escherica coli* or *S. cerevisiae* (yeast) is massive, composed of thousands of metabolites and reactions regulated by hundreds of genes, which interact with each other in a combinatorial fashion to maintain the cell's living state (Figure 1).

Recent advances in computer technology and bioinformatics have allowed for detailed analyses of these metabolic systems. Examples include the creation of metabolic models for organisms such as *E. coli* and *S. cerevisiae* in languages such as SBML (systems biology markup language), and the development of algorithms to identify nontrivial bottleneck reactions in these models. However, due to a lack of visual abstraction capabilities, procedures for the systematic and precise design (i.e., modification and construction) of metabolic networks are not as straightforward and predictable as they should be. For example, while engineers have algorithms to process a metabolic network and identify reactions of interest, the results are not automatically carried through to visual diagrams showing where the reactions are located within the overall metabolic system.

State-of-the-art metabolic engineering procedures apply an understanding of reaction kinetics from chemical engineering to the chemical networks and compounds of cells from the biological domain. Value in metabolic systems is generated by maximizing production rate of a metabolite of interest or maximizing carbon flux through its synthesis pathway, while minimizing energy cost associated with

compounds such as ATP (adenosine triphosphate) and NAD(P)H (Nicotinamide adenine dinucleotide (phosphate)). Metabolic engineers identify and investigate how specific modifications to the metabolic network (e.g., reaction knockouts or gene overexpression) result in redirection of carbon traffic in the system as a whole. Computational analysis and linear programming methods are used to simulate and predict experimental results while genetic engineering is used to implement the design. Unfortunately, this process requires extensive human input and is time consuming. One source of inefficiency stems from less-than-perfect algorithms sometimes suggesting reactions whose modifications result in cell death, or whose modifications are impossible to implement through genetic engineering. This puts researchers in a position where code may need to be rewritten multiple times before it outputs reaction modifications that are experimentally feasible.

Overcoming these limitations will require new approaches to identifying and handling design modifications such as reaction knockouts. Reaction knockouts are a type of modification to a metabolic network in which a reaction is eliminated and a pathway becomes a dead end. Since carbon cannot flow through an interrupted pathway, the flux is often rerouted through other pathways in the metabolic network. When applied strategically, reaction knockouts can reroute flux towards a targeted pathway. However, reaction knockouts vary in impact, ranging from no effect on reaction flux (e.g., if the knockout reaction is on a pathway in parallel with other paths) to total reduction of all cellular flux to zero, also known as cell death (e.g., if a reaction is in a main branch of the network). A second source of difficulty stems from the non-additive nature of reaction knockouts. This occurs due to flux interactions. As a result,

design procedures based upon sequences of individual knockouts are sometimes less than optimal. To overcome this barrier, design procedures need to handle combinations of knockouts. When this fact is coupled with large network size, the complexity of the design space explodes in combinatorial fashion. This results in an algorithm's application becoming much more computationally intensive and time consuming.

To see how the high degree of interconnectivity between biological nodes creates combinatorial explosion, consider a 3 knockout experiment of 500 reactions. This corresponds to ${}_{n}C_r = {}_{500}C_3 = 20,708,500$ knockout combinations. If the designer wanted to complete 3 knockouts on a higher-level organism with 900 reactions, knockout combinations increase to ${}_{n}C_r = {}_{500}C_3 = 121,095,300$. Increasing the number of knockouts further to 6, gives ${}_{n}C_r = {}_{500}C_6 = 21,057,686,727,000$ possibilities. This rapid growth in possible combinations creates a gap between what is required from a system perspective, and what is possible from a design and validation perspective. Smarter approaches to computational metabolic engineering would incorporate knowledge of dependencies among metabolites, and employ combinations of “system decomposition and abstraction” to keep the complexities of metabolic computations in check.

1.2 – Scope and Objectives

When working with complex biological systems, metabolic engineers continually seek new approaches to the synthesis, design, and assessment of system-level architectures. For example, scientists have suggested that the biological community needs to lay broad foundations with respect to the concepts of standardization, decoupling and abstraction (*Endy 2005*). Still, many questions remain. How, for example, can one design metabolic processes with less human intervention

and greater efficiency through automation? What kinds of design tools will work for extremely large biological systems? We hypothesize that various forms of assistance will be useful to the metabolic engineering and greater biological community. Assistance can be provided in the form of design principles (e.g., rules of development) and building blocks upon which good design solutions can be built. Designers also need mechanisms to: (1) Dynamically control the levels of detail that will be presented to an engineer, and (2) Dynamically reconfigure statements of system functionality in response to the identification of designer mistakes and/or changes in required functionality.

This thesis has two purposes. In Chapter 2, we propose a multi-level framework for the synthesis, analysis and design of metabolic systems. This framework will employ a variety of modeling abstractions, approaches to design specification, and strategies for systems integration. In Chapter 3, we apply this framework to a metabolic engineering experiment in which the objective is to optimize a yeast strain genetically engineered to produce artemisinin via reaction knockouts. We will pay special attention to semiformal models of visual abstraction and interfacing them with more formal models of simulation. This is an area with strong precedents in systems engineering, but limited development in the metabolic engineering space. In Chapter 4, we will present a summary of the work and suggestions for future research. Scripts of the MATLAB code for the *in silico* experiment can be found in Appendix A.

Chapter 2 – Multi-Level Framework for Orchestration of Good Design Solutions

2.1 – Approach

Metabolic systems are complex heterogeneous systems developed by teams of researchers, many of whom will have expertise in only one or two aspects of biology (e.g., cell biology; functional genomics; genetics, microbiology, bioinformatics etc.). To this end, and in support of the synthesis, design, integration, and evaluation of metabolic systems, this chapter formulates a multi-level framework for the orchestration of good design solutions. We expect that high levels of productivity will be achieved through the use of high-level visual abstractions coupled with lower-level (mathematical) abstractions suitable for formal systems analysis.

2.1.1 - Strategies for Dealing with Increases in System Complexity

From both a scientific and engineering perspective, metabolic networks are immensely complex systems characterized by large numbers of nodes (chemical compounds, hereafter referred to as metabolites), and interconnections (reactions). History tells us that as technologies improve over time, scientists are provided with better tools to conduct experimental observations and collect experimental data. This, in turn, allows for the formulation of new hypotheses aimed at explaining the mechanisms and dynamics behind experimental observations. After more than five decades of modern biological research, we are now entering an era where mathematical modeling of biological and biochemical systems can provide insight into the system structure (e.g., organs, tissues, cells and molecules, connections among components) and system behavior (e.g., detailed dynamics of biochemical interactions; built in control/defense

mechanisms to provide protection against environmental attack) (Tomlin 2005, Tomlin 2007).

From a systems engineering perspective, biologists are not designing and creating more complicated systems per se - instead, they observe systems in the hope of creating a better understanding of the architecture, behavior, and control mechanisms in the biological system. The associated increase in observational complexity over time is shown in Figure 2. We assume that in the beginning, scientific studies will lead to large improvements in knowledge and understanding of the biological system, but that longer term, further studies will produce diminishing returns.

One consequence of these advances is an ongoing desire to apply metabolic engineering in higher level organisms, with each iteration of design and development being more complex than its predecessors. Figure 3 summarizes the key challenges designers of metabolic processes will face over time. First, using state-of-the-art approaches to design, there is an upper limit to system complexity that can be designed and validated in an acceptable amount of time. New approaches to design are needed to improve designer productivity and minimize the gap between our capability and what is actually feasible from a design and validation point of view.

Biological Systems Viewpoint

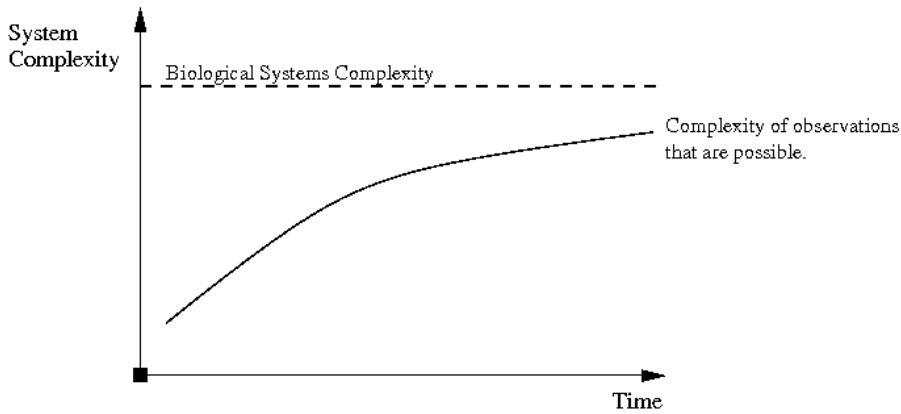

Figure 2 – Sources of complexity from a biological systems viewpoint

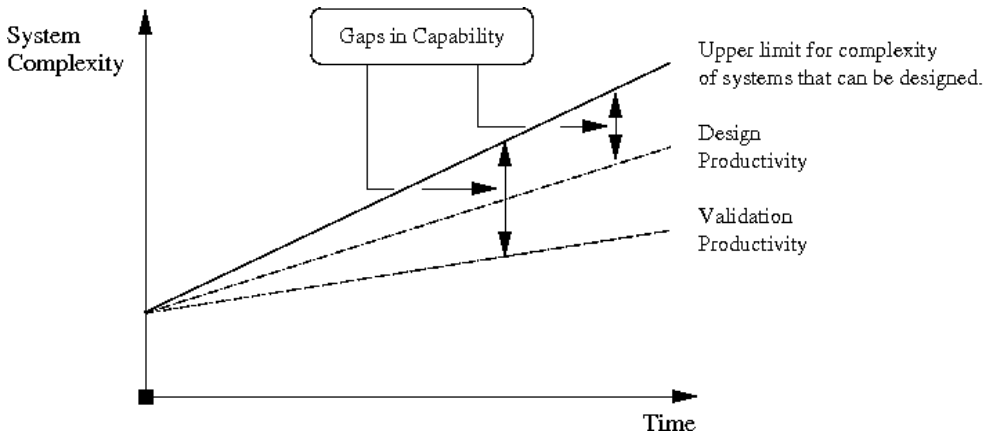

Figure 3 - Sources of complexity from a metabolic systems design viewpoint

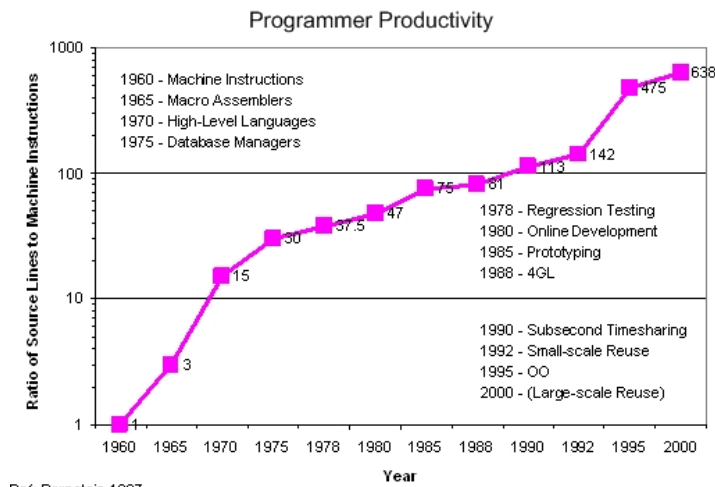

Figure 4 - Increases in programmer productivity over time (Austin 2011)

Fortunately, we can learn a lot about the pathway forward by looking to successes from the past. History tells us that major increases in productivity are almost always accompanied by problem-solving at higher levels of abstraction. As illustrated in Figure 4, within the software world, remarkable increases in programmer productivity have been achieved through the use of high-level languages (e.g., Java, Python, UML) coupled with compiler technologies for the automated transformation of high-level abstractions into equivalent lower level abstractions (e.g., automated code generation, byte codes and machine codes), and machine infrastructures for software execution (e.g., Java Virtual Machine). Naturally, professionals in both the systems engineering and metabolic engineering communities would like a pathway forward for achieving similar increases in attainable productivity.

2.1.2 - Solution Mechanisms

Experience tells us that good solutions are likely to employ a combination of the following mechanisms:

- *Semi-Formal Models*. To allow for the efficient description of ideas (e.g., goals and scenarios, tentative design concepts), textual and visual representations need to be based on semi-formal models (e.g, Unified Modeling Languages (UML) and Systems Modeling Languages (SysML)) having well defined syntax and semantics.
- *Formal Models*. To help prevent serious flaws in detailed design and operation, design representations and validation/verification procedures need to be based on formal languages having precise semantics.

- *Abstraction.* Abstraction mechanisms eliminate details that are of no importance when evaluating system functionality, system performance, and/or checking that a design satisfies a particular property. When we discuss the effectiveness of an abstraction, we are focusing on two particular concepts: (1) information hiding, and (2) encapsulation. By information hiding, we are referring to the omission of all irrelevant details. By encapsulation, we are referring to the grouping of processes or concepts together in a logical way. It often goes hand in hand with information hiding, as by grouping a set of items together, we can often condense them under the group heading and free up space in the diagram for other uses.
- *Decomposition.* Decomposition is the process of breaking a design at a given level of hierarchy into subsystems and components that can be designed and verified almost independently.
- *Composition.* Composition is the process of systematically assembling a system from subsystems and components. We seek, in particular, methods that allow for the systematic assembly of behavior models for complex systems from behavior models for simpler systems and components.

(coupled with strategies of systems engineering development (e.g., separation of logical and physical concerns; breadth before depth) refined over many years).

Semi-formal models are appropriate for the early stages of development, especially when a complete system description does not exist. At first, the central concern is making sure the right product or process will be designed. For projects that are new and innovative, the system engineer will need to work with the stakeholders

simply to figure out what the system will do, the scenarios corresponding to goals, and strategies for handling unexpected events. This activity is called goals and scenario analysis. The use of visual modeling abstractions, such as UML and SysML helps to reduce the risk of failure by forcing engineers to state all of their assumptions and think systematically about how the fragments of system behavior will be translated into flows of control and sequences of functionality. Development of the system structure description will include identification of the major subsystems, their connectivity to other subsystems, and connectivity to the surrounding environment. A second purpose for visual modeling abstractions is to act as an enabling formalism for the integration of models developed for different purposes.

Formal models of analysis are appropriate for the simulation, evaluation, and optimization-based design of detailed design descriptions, where decisions on high-level behavior and structure need to be refined to include data/information relevant to a specific discipline (e.g., the chemistry and physics of metabolic processes). Formal models for engineering design should consist of the following components (Sangiovanni-Vincentelli, 1996):

- A set of explicit or implicit equations which involve input, output and possible internal (state) variables;
- A set of properties that the design must satisfy given as a set of equations over design variables (inputs, outputs, states);
- A set of performance indices which evaluate the quality of the design in terms of cost, reliability, speed, etc. given as a set of equations involving design variables.

- A set of constraints on design variables and on performance indices specified as a set of inequalities.

Appropriate formalisms will depend on the domain of interest. For our purposes, we will incorporate the chemistry and physics of metabolic engineering processes, thereby allowing for: (1) The quantitative evaluation of metabolic system performance and cost, and (2) A framework for defining and searching the design space of potentially good solutions.

Semi-formal and formal modeling abstractions are developed to support design processes that are part top-down and part bottom-up. Top-down approaches to development assume that a complicated design problem can be simplified through its decomposition into a network of simpler design problems. A key advantage for top-down approaches to design is built-in support for customization. The key disadvantage of top-down approaches to design is that processes always start from scratch – since there is no attempt to reuse previous work, schedules of development may be unnecessarily long. Bottom-up approaches to development assume that good design solutions can be created through the assembly or composition of previously defined components or building blocks. The key advantages of bottom-up development are reduced time to market and improved quality (because building blocks will have been tested in previous iterations of development).

2.1.3 - Multi-Level Framework for Metabolic Process Design

We propose that the mechanisms of semi-formal and formal modeling, and top-down and bottom-up approaches to design be combined in a single multi-level framework as shown in Figure 5.

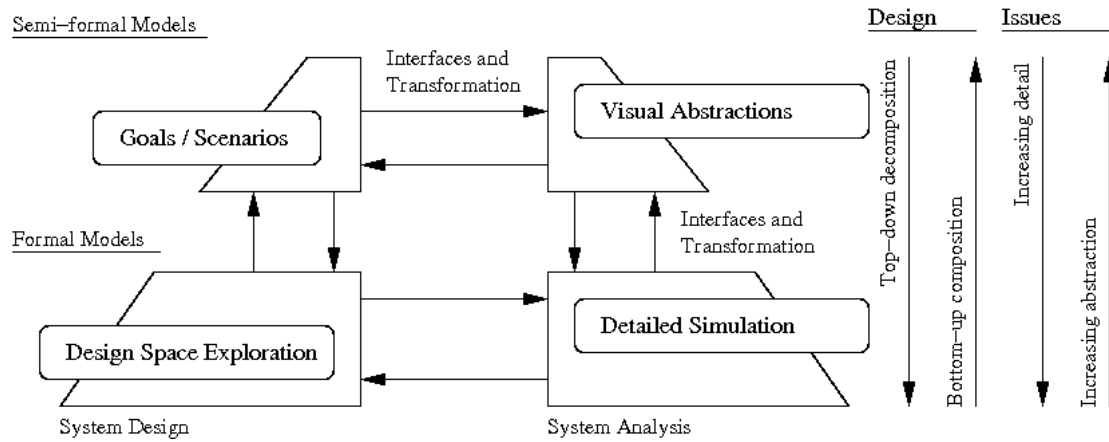

Figure 5 - A Multi-level framework for synthesis, analysis, design and integration of models in metabolic system design.

The design of metabolic processes will be part top-down decomposition (e.g., customized specification metabolic pathways) and part bottom-up composition of previously designed biochemical blocks. As a designer moves from the semi-formal to formal layers, levels of design detail will increase and reliance on abstractions will decrease. Conversely, moving from the detailed design layer to the higher-level layer relying on visual abstractions will correspond to an increasing reliance on abstractions and an increased focus on integration of models.

Recent research has demonstrated the use of SysML as a successful centerpiece abstraction for team-based system development, with a variety of interfaces and relationship types (e.g., parametric, logical and dependency) providing linkages to detailed discipline-specific analyses and orchestration of system engineering activities. (*Bajaj et al, 2011*). In the long term, however, we believe that multiple models of visualization will be required (e.g, combinations of SysML and SBGN), with graphical formalisms displaying concepts in a notation familiar to the end user.

To support the broader exploration of design spaces, for example, a long-term goal is to find ways of connecting algorithms for design space exploration with those for performance assessment of metabolic processes. We also need tools for the automated transformation of high-level representations into lower-level schematics for detailed implementation, and for automated transformation between visual representations (e.g., SysML to SBGN where similarities exist). Finally, we envision the use of optimization-based design tools that will assist a designer in the efficient exploration of a design space. Subsystems will be integrated together by connecting interface representations for each of the participating subsystems.

2.1.4 - Systems Integration

System integration is the process of bringing together the component subsystems into one system and ensuring that the subsystems function together as a single system. To simplify the design and management of the system operation, these subsystems will have interfaces that expose to the outside world the mechanisms for communication and hide internally, the mechanisms of subsystem functionality. Thus, integration can be viewed as joining the subsystems together by gluing their interfaces together. If the interfaces do not interlock directly, then adapters can be designed to provide the required mappings (or glue).

Figure 6 (an extension of Figure 5) shows the details for how high-level visual modeling languages, such as SysML, can act as the glue for the integration of formal models for guided design space exploration and detailed simulation. By itself, SysML

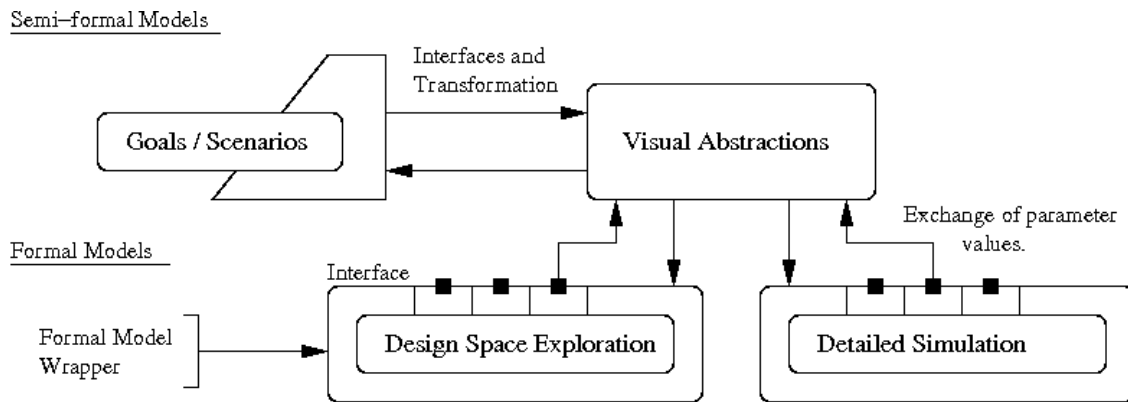

Figure 6 - Framework for integration of semi-formal models with formal models

enables systems integration through its use of requirements diagrams, structural constructs, and parametric, logical, and dependency relationships. The hope is that SysML will also be a suitable abstract visual representation for metabolic systems, with the potential to interface with algorithms such as OPTKNOCK, and FBA simulations as they are implemented in MATLAB (details to follow in Chapter 3).

2.2 – Semi-Formal Models for Metabolic Engineering

Standardized graphical representations, such as the Systems Modeling Language (SysML) or Systems Biology Graphical Notation (SBGN) provide a means to describe products of conceptual design such as models of system functionality and high-level requirements.

2.2.1- Goals and Scenarios

The primary design goal for this work is efficient production of a metabolite of interest within a metabolic system subject to rigid constraints for homeostasis (life-maintaining processes). Restated, in order for a metabolic system to be considered functional, the cell cannot die! Modifying metabolic systems for the purpose of

increasing or decreasing formation of certain metabolites falls under performance requirements. Metabolic engineering experiments tend to be oriented towards optimization of target metabolites while still maintaining a cell's living state.

2.2.2 – Abstraction: Ad Hoc Metabolic Engineering Diagrams

Within the biochemical community, SBGN (Systems Biology Graphical Notation) provides a family of language for shown process flow, entity relationships and flows of information. For example, the SBGN Process Description Language provides a standardized graphical notation for showing the temporal courses of biochemical/molecular interactions taking place in a network of biochemical entities.

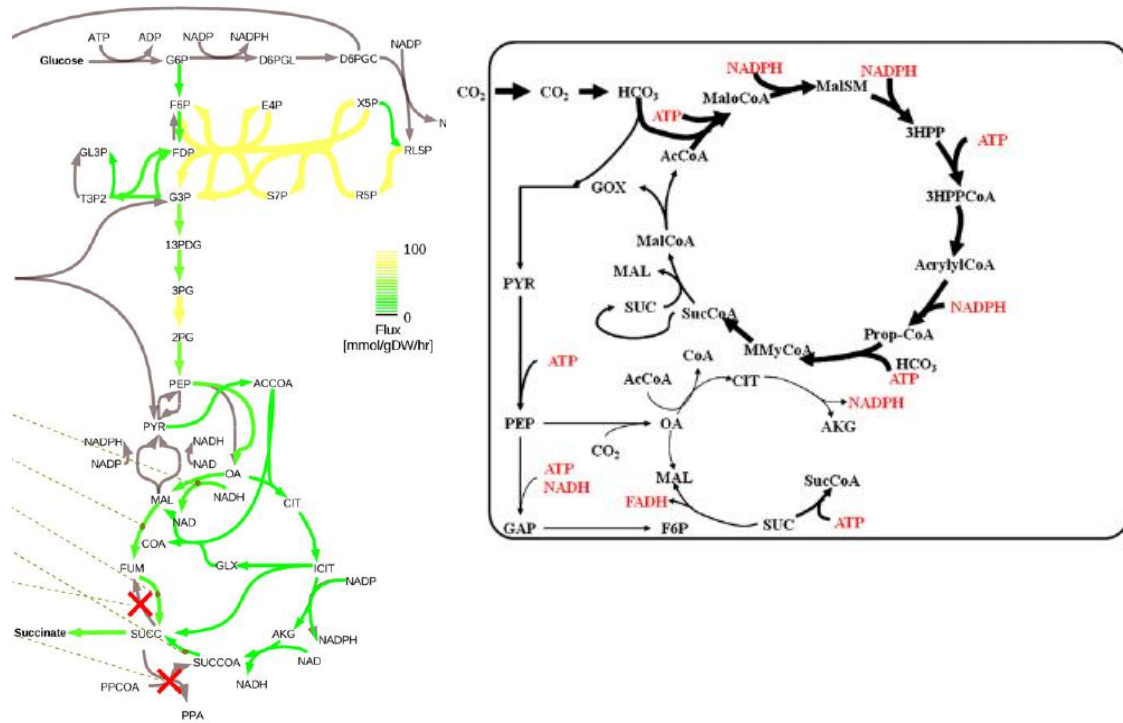

Figure 7 - Metabolic Engineering Diagrams (Yang et al, 2011; Boyle et al, 2011)

While most metabolic engineering diagrams do not adhere to a particular standard, there are some common design principles that researchers do tend to follow when presenting their data in the field. One of the most important metrics for metabolic engineers is metabolic flux. Metabolic flux can also be thought of as the flow rates at which reactions proceed, or also the flow of carbon atoms through a series of reactions. For this reason, metabolic engineers place primary emphasis on showing the metabolic flux through a system, and secondary emphasis on showing the system itself. A common way to show differences in flow is through size, color, and shape (*Agrawala et al, 2011*). The examples from Figure 7 demonstrate this. On the left side, grey represents zero flow, green represents low flow, and yellow represents high flow. On the right side, the size of the arrows represents flow rate, with thicker arrows indicating higher activity. While this method works well on an *ad hoc* basis, it is not device independent (i.e., it is easily affected by rescaling and/or photocopying). Lack of a standard has resulted in a plethora of different diagram types and formats with individual syntax and semantics.

2.2.3 - Abstractions: SBGN

SBGN is the result of efforts from the biological community to develop a standardized visual language for the greater biological community, one that overcomes the shortcomings of ad hoc visual languages used in previous generations of work. A summary of these shortcomings can be found in Table 1. In order to address these problems, the SBGN development community created three types of visual languages: (1) Process diagrams, (2) Entity relationship diagrams, and (3) Activity flow diagrams. Examples of all three are seen in

Figure 8, along with a summary of the relative advantages and disadvantages of each one (Table 2).

Table 1 - Features and problems of ad hoc graphical notations (Novere et al, 2009)

Feature	Problem(s)
Different line thicknesses distinguish different types of processes or elements Dotted or dashed line styles distinguish different types of processes or elements	<ol style="list-style-type: none"> 1. Rescaling a diagram can make line thicknesses and styles impossible to discern 2. Photocopying or faxing a diagram can cause differences in line thicknesses and styles to disappear 3. Differences in line thickness and style are difficult to make consistent in diagrams drawn by hand
Different colors distinguish different types of processes or elements	<ol style="list-style-type: none"> 1. Photocopying or faxing a diagram will cause color differences to be indistinguishable 2. color characteristics are difficult to achieve and keep consistent when drawing diagrams by hand
Identical line terminators (e.g., a single arrow) indicate different effects or processes depending on context	<ol style="list-style-type: none"> 1. Greater ambiguity is introduced into a diagram 2. Interpreting a diagram requires more thought on the part of the reader 3. Automated verification of diagrams is more difficult due to lack of distinction between different processes or elements
<i>Ad hoc</i> symbols introduced at will by author	Interpreting a diagram requires the reader to search for additional information explaining the meaning of the symbols.

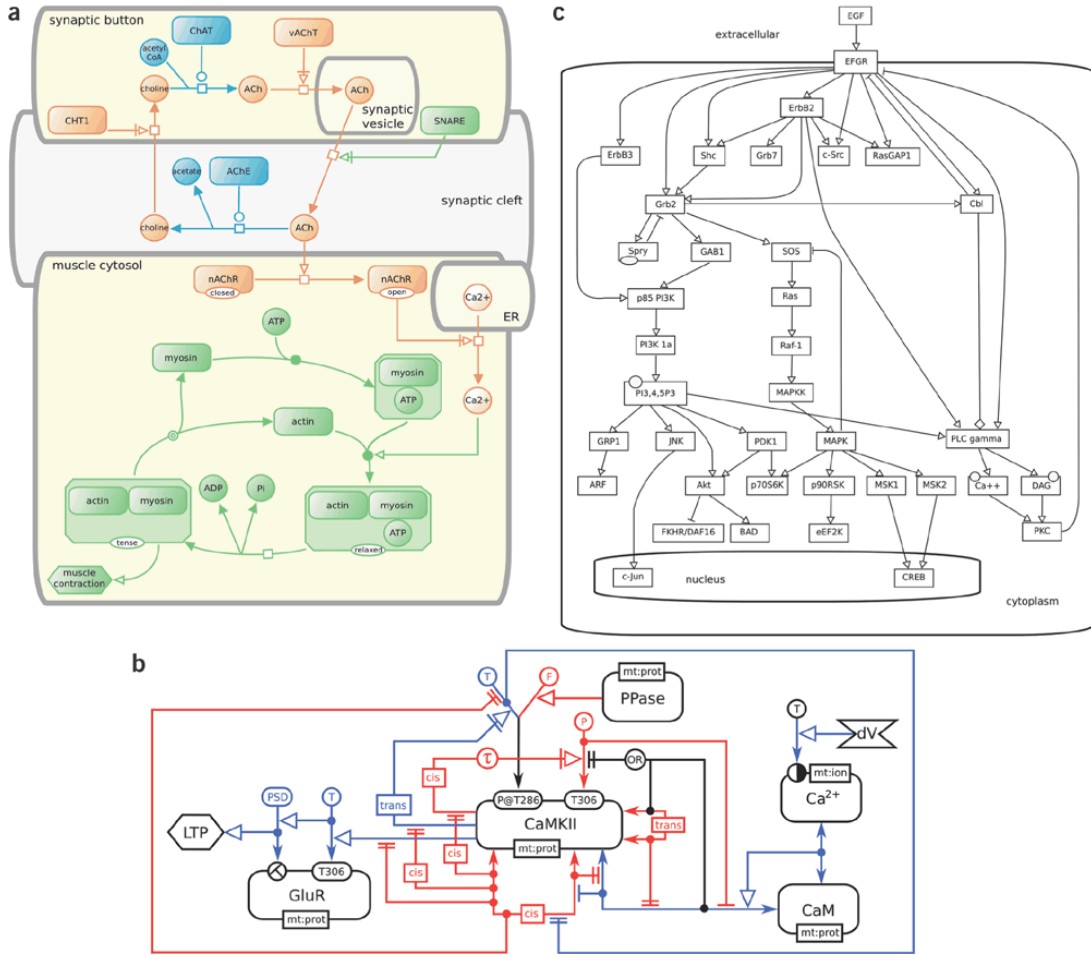

Figure 8 - SBGN examples: (a) process diagram, (b) entity relationship diagram, (c) SBGN activity flow diagram (Novere et al, 2009).

Table 2 - Comparison between the three languages of SBGN (*Novere et al, 2009*)

	Process diagram	Entity relationship diagram	Activity Flow diagram
Purpose	Represent processes that convert physical entities into other entities, change their states, or change their location	Represent the interactions between entities and the rules that control them	Represent the influence of biological activities on each other
Building Block	Different states of physical entities are represented separately	Physical entities are represented only once	Different activities of physical entities are represented separately
Ambiguity	Unambiguous transcription into biochemical events	Unambiguous transcription into biochemical events	Ambiguous interpretation in biochemical terms
Level of Description	Mechanistic descriptions of processes	Mechanistic description of relationships	Conceptual description of influences
Temporality	Representation of sequential events	Absence of sequentiality between events	Representation of sequential influences
Pitfalls	Sensitive to combinatorial explosion of states and processes	Creation, destruction, and translocation are not easily represented	Not suitable to represent association, dissociation, multistate entities
Advantages	the best for representing temporal/mechanistic aspects of processes such as metabolism	The best for representing signaling involving multistate entities	The best for functional genomics and signaling with simple activities

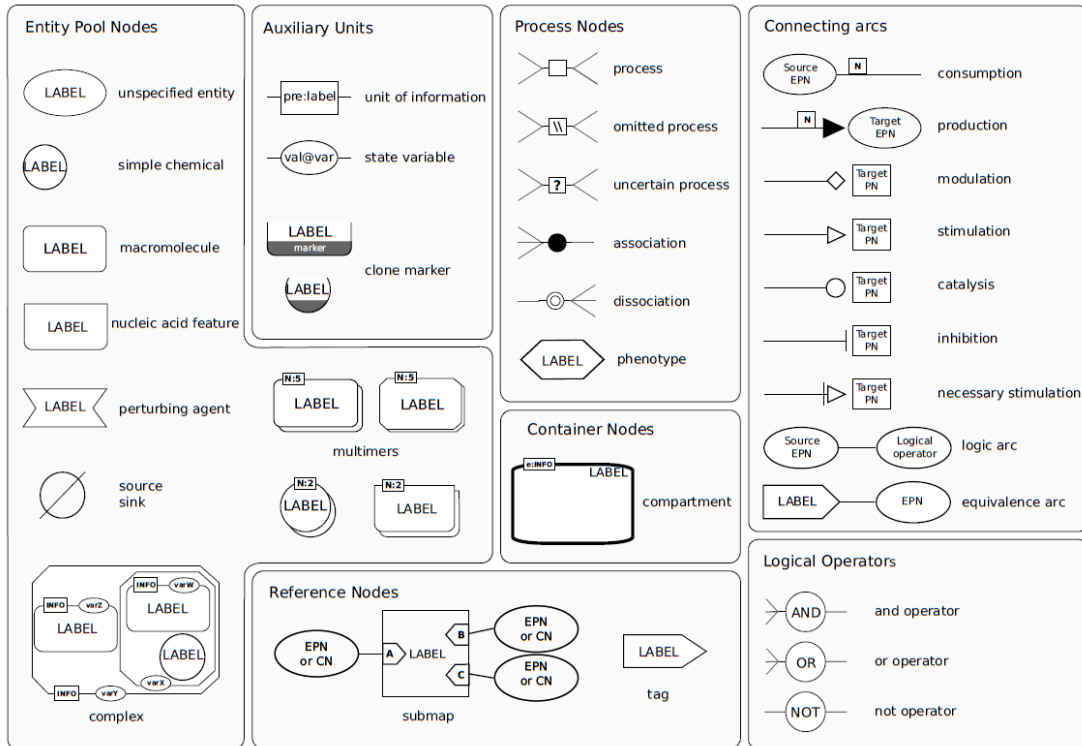

Figure 10 - Glyphs for SBGN Process Diagrams

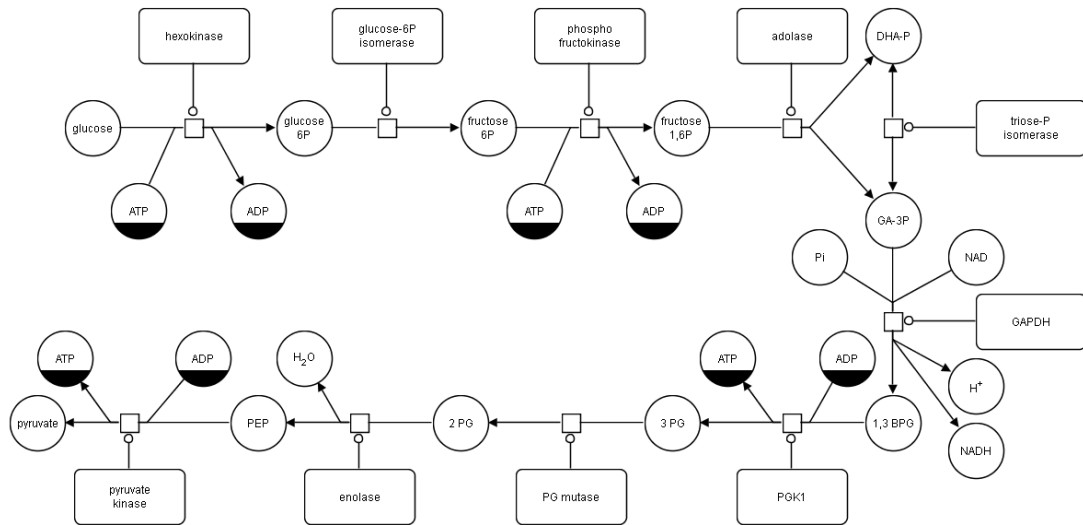

Figure 9 - SBGN Process diagram for Glycolysis

Summary of SBGN Process Diagram Notation. Figure 10 is a reference card which describes the various types of glyphs specific to the process diagram language of SBGN, and Figure 9 is a depiction of glycolysis using the process diagram language. These are included to give the reader some familiarity with how to read SBGN diagrams, which will be used in Chapter 3 to represent the experimental results.

The process diagram shows the transformation of glucose to glucose-6-phosphate, to fructose-6-phosphate, etc. all the way through to pyruvate in the metabolic process of glycolysis. These are all simple chemicals represented by circles. Each reaction is a process represented by a square, and each step is catalyzed by a more complex macromolecule enzyme. Catalysis is represented by small circles near squares and macromolecules are represented by rounded rectangles. Repeated molecules, such as ATP, are partially filled in.

The notation is designed so that a user can see with a quick glance what the main enzymes are, what the commonly repeated molecules are, what the main reactants are and how they fit together in the process of glycolysis.

2.2.4 - Abstractions: SysML

The Systems Engineering Markup Language, SysML, is a standard visual language for communication of system development product and process concepts, such as requirements, models of system behavior and structure, and support for parametric studies.

The concepts of SysML build upon those of UML (the Unified Modeling Language), a similar visual language for communication of software products and processes. UML was developed by the Object Management Group during the 1990s. SysML was also developed by the Object Management Group, but during the 2002-2005 time frame. During the past two decades, UML has evolved to meet the expanding demands of the software community. For example, UML 2 added features to support the development of software for real-time systems. To our knowledge, however, SysML has not been used to model biological systems.

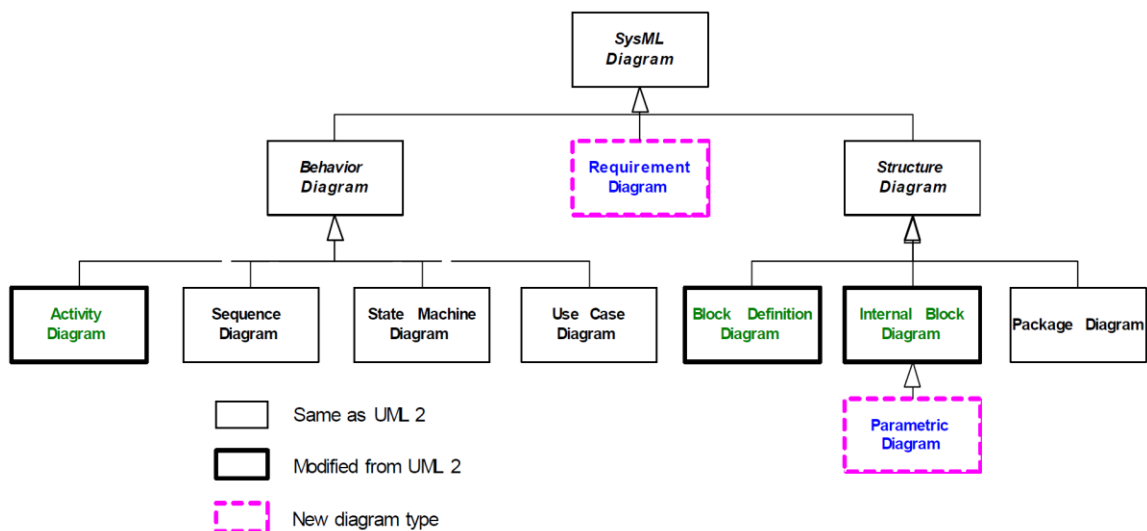

Figure 11 - SysML Taxonomy (OMG: SysML v 1.2, 2010)

The primary uses for UML and SysML are to provide engineers with a collection of visual formalisms (i.e., types of diagrams) to express system behavior and architecture in the form of entities, processes, activities, components, and relationships between components. SysML can be subdivided into three groups of support (as shown in Figure 11): (1) Structural constructs, which tend to take the form of block diagrams

and depict the components of a system, (2) Behavioral constructs, which depict the interactions between components of a system, and (3) Requirement diagrams. Note that it is possible to create diagrams which combine both structural and behavioral constructs, e.g., nesting a state machine inside a block.

Focus on internal block and parametric diagrams. It is generally accepted that metabolic flux is a key parameter in metabolic engineering. The process flows and transformation reactions can be represented as a hierarchical graph of blocks, ports, and connections. In order to successfully integrate the constraints as defined by metabolic flux into a SysML diagram, it makes sense that we use internal block diagrams and at a more detailed level, parametric diagrams.

To see how this might work in practice, Figure 12 and Figure 13 are SysML compliant internal block diagram and parametric diagram depictions of a **distiller example**, as developed in the text of Friedenthal 2009.

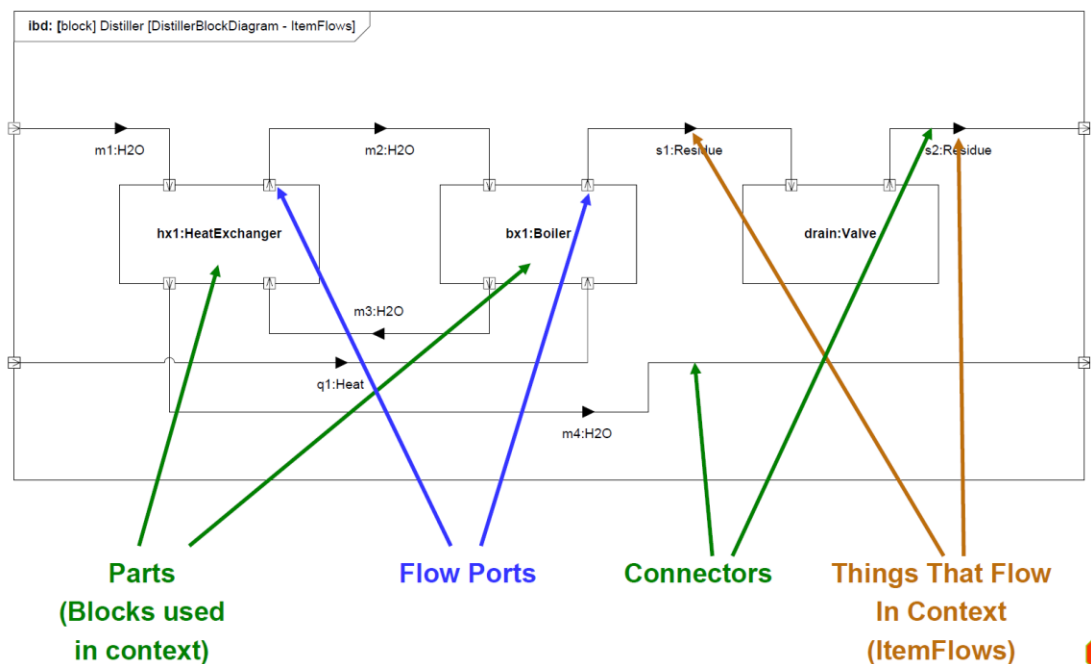

Figure 12 - Internal Block Diagram of a Distiller (Friedenthal et al, 2009)

One can see from Figure 12 how the distiller works. There are three types of flows: H2O, Heat, and Residue, and three major components: a heat exchanger, a boiler, and a drain. Heat flows into the system and to the boiler. Water flows through two loops. The first loop flows into the system, through the heat exchanger, and then out of the system. The second loop is a closed loop flowing between the heat exchanger and the boiler. Residue flows from the boiler out of the system through a drain valve.

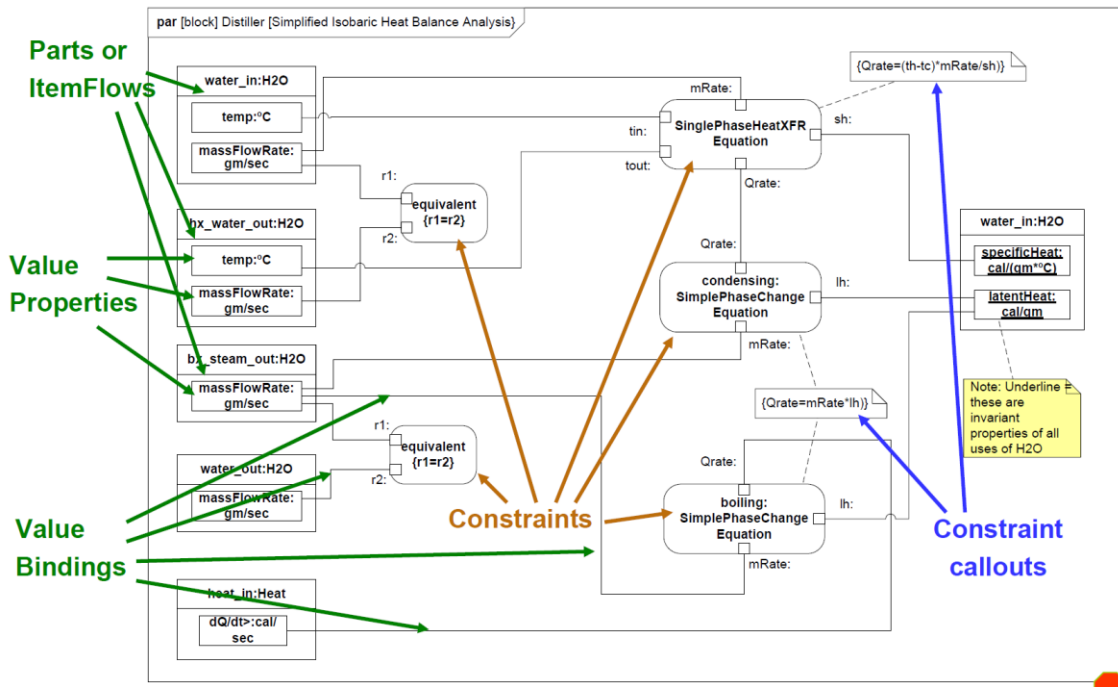

Figure 13 - Parametric Diagram of a Distiller (Friedenthal et al, 2009)

Figure 13 also represents the distiller. However, its emphasis is on describing the parameters which describe the material flows in Figure 12. For each item flow, there is a list of value properties and value bindings, e.g., temperature and flow rate properties. Additionally, each of these listed item flows is linked to multiple constraints which can be called out with defining equations and proportionalities.

Thus, while a biology-specific layer of SysML does not exist, our experience with metabolic engineering suggests that Internal Block Diagrams with potential

parametric specifications and constraints would be the best SysML notation for representing metabolic systems.

2.3 - Formal Models for Metabolic Engineering

For metabolic engineering, formal models are needed for the accurate and quantitative evaluation of system behavior (e.g., metabolic process production) and efficient design space exploration. The best formal model system analysis tool that allows for detailed simulations of metabolic systems is flux balance analysis (FBA). By optimizing for biomass, and setting the parameters so that they reflect the reactions which have been modified, one can get a good idea for how a metabolic system will perform.

Design space exploration takes the form of various algorithms which can winnow the metabolic landscape down and identify key bottleneck reactions which can be modified to redirect cellular traffic towards pathways of interest. Examples of such algorithms include GDLS (*Lun et al, 2009*), EMILiO (*Yang et al, 2011*), OptORF (*Kim et al, 2010*) and OPTKNOCK (*Burgard et al, 2003*). The general purpose of these algorithms is to apply a linear programming based framework which will identify key reactions or genes whose modification (in the form of knockouts or overexpression) will result in optimization of a target metabolite. As the oldest of the algorithms mentioned, OPTKNOCK has become the standard benchmark algorithm within metabolic engineering.

2.3.1 - Flux Balance Analysis

Expressing a biological system in mathematical terms enables the researcher to use linear algebra to find mathematical solutions for experimental problems at a high

level of abstraction. Consider Figure 14. Visually, a researcher can see from the diagram that the flux r_0 breaks into two flux branches, r_1 and r_2 . The r_1 flux continues to the r_3 flux, and the r_2 flux continues to the r_4 flux. Thus, $r_1=r_3$, $r_2=r_4$, $r_1+r_2=r_0$, and $r_3+r_4=0$. Figure 15 verifies this mathematically. While the flux through the network in Figure 14 is easy to visualize, as networks become more complex, convoluted, and interconnected, we have to rely increasingly on mathematical abstraction for analysis. The standard method of mathematically representing a genome scale system and predicting biomass formation is the process known as flux balance analysis.

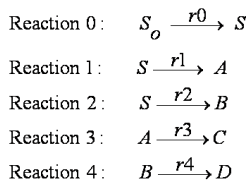
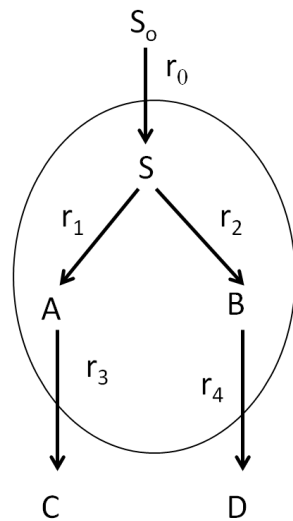

$$\begin{aligned} \frac{dS_0}{dt} &= -r_0 \\ \frac{dS}{dt} &= r_0 - r_1 - r_2 \\ \frac{dA}{dt} &= r_1 - r_3 \\ \frac{dB}{dt} &= r_2 - r_4 \\ \frac{dC}{dt} &= r_3 \\ \frac{dD}{dt} &= r_4 \end{aligned}$$

$$\frac{d}{dt} \begin{bmatrix} S_0 \\ S \\ A \\ B \\ C \\ D \end{bmatrix} = \begin{bmatrix} -1 & 0 & 0 & 0 & 0 \\ 1 & -1 & -1 & 0 & 0 \\ 0 & 1 & 0 & -1 & 0 \\ 0 & 0 & 1 & 0 & -1 \\ 0 & 0 & 0 & 1 & 0 \\ 0 & 0 & 0 & 0 & 1 \end{bmatrix} \begin{bmatrix} r_0 \\ r_1 \\ r_2 \\ r_3 \\ r_4 \end{bmatrix}$$

$$\frac{d}{dt} x = Sv$$

$$x = \begin{bmatrix} S_0 \\ S \\ A \\ B \\ C \\ D \end{bmatrix} \quad S = \begin{bmatrix} -1 & 0 & 0 & 0 & 0 \\ 1 & -1 & -1 & 0 & 0 \\ 0 & 1 & 0 & -1 & 0 \\ 0 & 0 & 1 & 0 & -1 \\ 0 & 0 & 0 & 1 & 0 \\ 0 & 0 & 0 & 0 & 1 \end{bmatrix} \quad v = \begin{bmatrix} r_0 \\ r_1 \\ r_2 \\ r_3 \\ r_4 \end{bmatrix}$$

Figure 14- How to translate a reaction network into a linear algebra expression with stoichiometric matrix and flux vector. (Athanasίου et al, 2003)

Assume steady state for the unknowns

$$\frac{d}{dt} \begin{bmatrix} S_o \\ S \\ A \\ B \\ C \\ D \end{bmatrix} = \begin{bmatrix} dS/dt \\ 0 \\ 0 \\ 0 \\ dC/dt \\ dD/dt \end{bmatrix} \begin{bmatrix} -1 & 0 & 0 & 0 & 0 \\ 1 & -1 & -1 & 0 & 0 \\ 0 & 1 & 0 & -1 & 0 \\ 0 & 0 & 1 & 0 & -1 \\ 0 & 0 & 0 & 1 & 0 \\ 0 & 0 & 0 & 0 & 1 \end{bmatrix} \begin{bmatrix} r_o \\ r_1 \\ r_2 \\ r_3 \\ r_4 \end{bmatrix}$$

$$\frac{d}{dt} \begin{bmatrix} S_o \\ C \\ D \end{bmatrix} = \begin{bmatrix} -1 & 0 & 0 & 0 & 0 \\ 0 & 0 & 0 & 1 & 0 \\ 0 & 0 & 0 & 0 & 1 \end{bmatrix} \begin{bmatrix} r_o \\ r_1 \\ r_2 \\ r_3 \\ r_4 \end{bmatrix} = \begin{bmatrix} -1 & 0 & 0 \\ 0 & 1 & 0 \\ 0 & 0 & 1 \end{bmatrix} \begin{bmatrix} r_o \\ r_3 \\ r_4 \end{bmatrix}$$

and

$$\begin{bmatrix} 0 \\ 0 \\ 0 \end{bmatrix} = \begin{bmatrix} 1 & -1 & -1 & 0 & 0 \\ 0 & 1 & 0 & -1 & 0 \\ 0 & 0 & 1 & 0 & -1 \end{bmatrix} \begin{bmatrix} r_o \\ r_1 \\ r_2 \\ r_3 \\ r_4 \end{bmatrix}$$

Estimate the intracellular fluxes, r_1 , and r_2 .

$$\begin{bmatrix} 0 \\ 0 \\ 0 \end{bmatrix} = \begin{bmatrix} 1 & -1 & -1 & 0 & 0 \\ 0 & 1 & 0 & -1 & 0 \\ 0 & 0 & 1 & 0 & -1 \end{bmatrix} \begin{bmatrix} r_o \\ r_1 \\ r_2 \\ r_3 \\ r_4 \end{bmatrix} (*) = \begin{bmatrix} 1 & -1 & -1 \\ 0 & 1 & 0 \\ 0 & 0 & 1 \end{bmatrix} \begin{bmatrix} r_o \\ r_1 \\ r_2 \end{bmatrix} + \begin{bmatrix} 0 & 0 \\ -1 & 0 \\ 0 & -1 \end{bmatrix} \begin{bmatrix} r_3 \\ r_4 \end{bmatrix}$$

$$\begin{bmatrix} r_o \\ r_1 \\ r_2 \end{bmatrix} = \begin{bmatrix} 1 & -1 & -1 \\ 0 & 1 & 0 \\ 0 & 0 & 1 \end{bmatrix}^{-1} \begin{bmatrix} 0 & 0 \\ 1 & 0 \\ 0 & 1 \end{bmatrix} \begin{bmatrix} r_3 \\ r_4 \end{bmatrix} \rightarrow \text{Use matrix inversion to solve}$$

$$= \begin{bmatrix} 1 & 1 & 1 \\ 0 & 1 & 0 \\ 0 & 0 & 1 \end{bmatrix} \begin{bmatrix} 0 & 0 \\ 1 & 0 \\ 0 & 1 \end{bmatrix} \begin{bmatrix} r_3 \\ r_4 \end{bmatrix} = \begin{bmatrix} 1 & 1 \\ 1 & 0 \\ 0 & 1 \end{bmatrix} \begin{bmatrix} r_3 \\ r_4 \end{bmatrix} = \begin{bmatrix} r_3 + r_4 \\ r_3 \\ r_4 \end{bmatrix}$$

$$\begin{bmatrix} r_o \\ r_1 \\ r_2 \end{bmatrix} = \begin{bmatrix} r_3 + r_4 \\ r_3 \\ r_4 \end{bmatrix}$$

Figure 15 - Applying Steady State and solving for fluxes using linear algebra (Athanasίου et al, 2003)

In order to understand flux balance analysis (which is essentially metabolic flux analysis at the genome scale), it helps to understand metabolic flux analysis. One takes a reaction network and breaks it down by reaction. Depending on whether a metabolite is produced or consumed, one can assign a positive or negative coefficient to the flux vector (which is equivalent to the rate of consumption/production) in the individual metabolite rate expressions. This coefficient will be the number expressed later in the stoichiometric matrix (where every row corresponds to the concentration of one compound, and every column corresponds to the flux of one reaction).

One can then set up a linear algebra equation of $dx/dt = Sv$, where dx/dt is the change in concentration of a column of reactants, S is the stoichiometric matrix (based on the coefficients for each individual reactant rate expression), and v is the flux through each reaction. The major assumption of metabolic flux analysis is that all internal metabolites have a steady state of 0. Since one can measure external

metabolites to obtain values, one can then set $dx/dt=0$ for the internal metabolites and solve for the unknown fluxes using linear algebra (Figure 14 and Figure 15).

Flux balance analysis is metabolic flux analysis at the genome scale (*Orth et al, 2010; Palsson, 2006*). The major concepts from metabolic flux analysis are still the same. S is still the stoichiometric matrix, and v is still the flux vector. Internal metabolites still have an assumed steady state of 0. However, there are now a much greater number of unknowns due to the larger system scale. With a larger system scale, the number of unknowns exceeds number of knowns, resulting in a solution space, and not a specific solution (Figure 16).

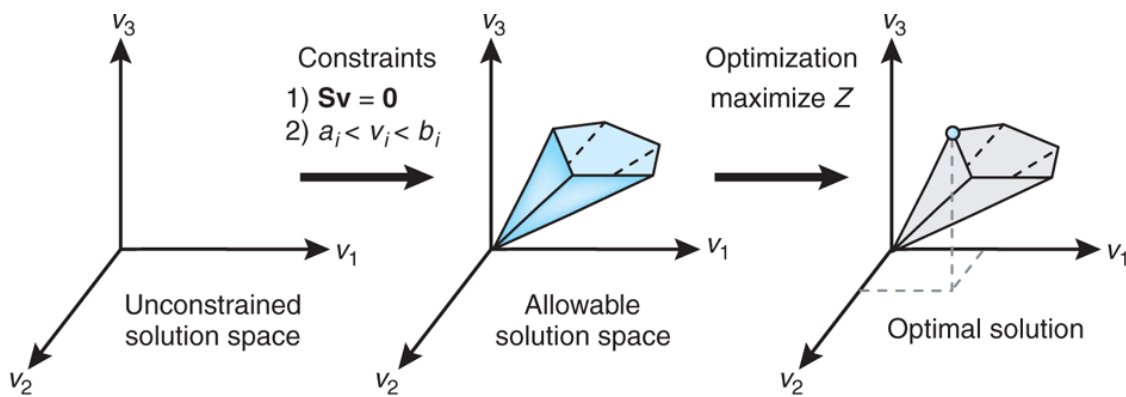

Figure 16 - Flux balance analysis – The allowable solution space is the set of all points satisfying all constraints. These constraints are represented by mass balance equations (which assure that any compound produced must equal the amount consumed at steady state) and capacity constraints (in the form of upper and lower bounds, which are usually based on experimental values). If a linear program has a non-empty bounded feasible region, then the optimal solution is always one of the corner points. (*Orth et al, 2010*).

In order to find an optimal solution within the solution space, one needs to apply constraints, set an objective function $c^T v = Z$, where c is a vector of weights indicating how much each reaction contributes to the objective function, and maximize the objective function. Ultimately, the objective function quantifies how much each reaction contributes to overall phenotype. The mathematical representations of the stoichiometric function and objective function set up a system of linear equations which

can be optimized using linear programming based algorithms to find the solution. Since the constraints define a non empty and bounded solution space, the optimal solution will always be at one of the corners (Figure 17 and Figure 18).

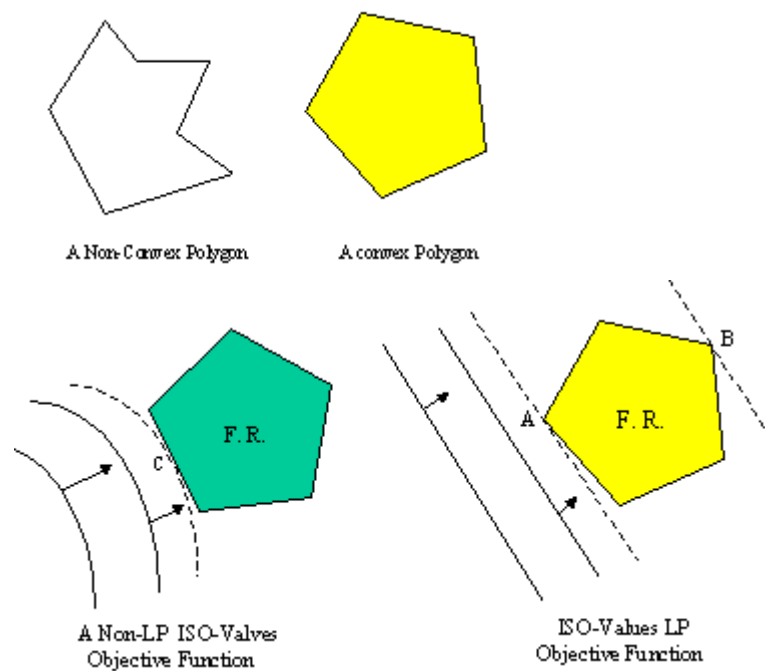

Figure 17 - (1) The feasible region of any linear program is always a convex set and (2) The iso-value line of a linear program objective function is always a linear function. Combining these two concepts, it follows that if a linear program has a non-empty, bounded feasible region, the optimal solution will always be one of the corner points (Arsham 2011).

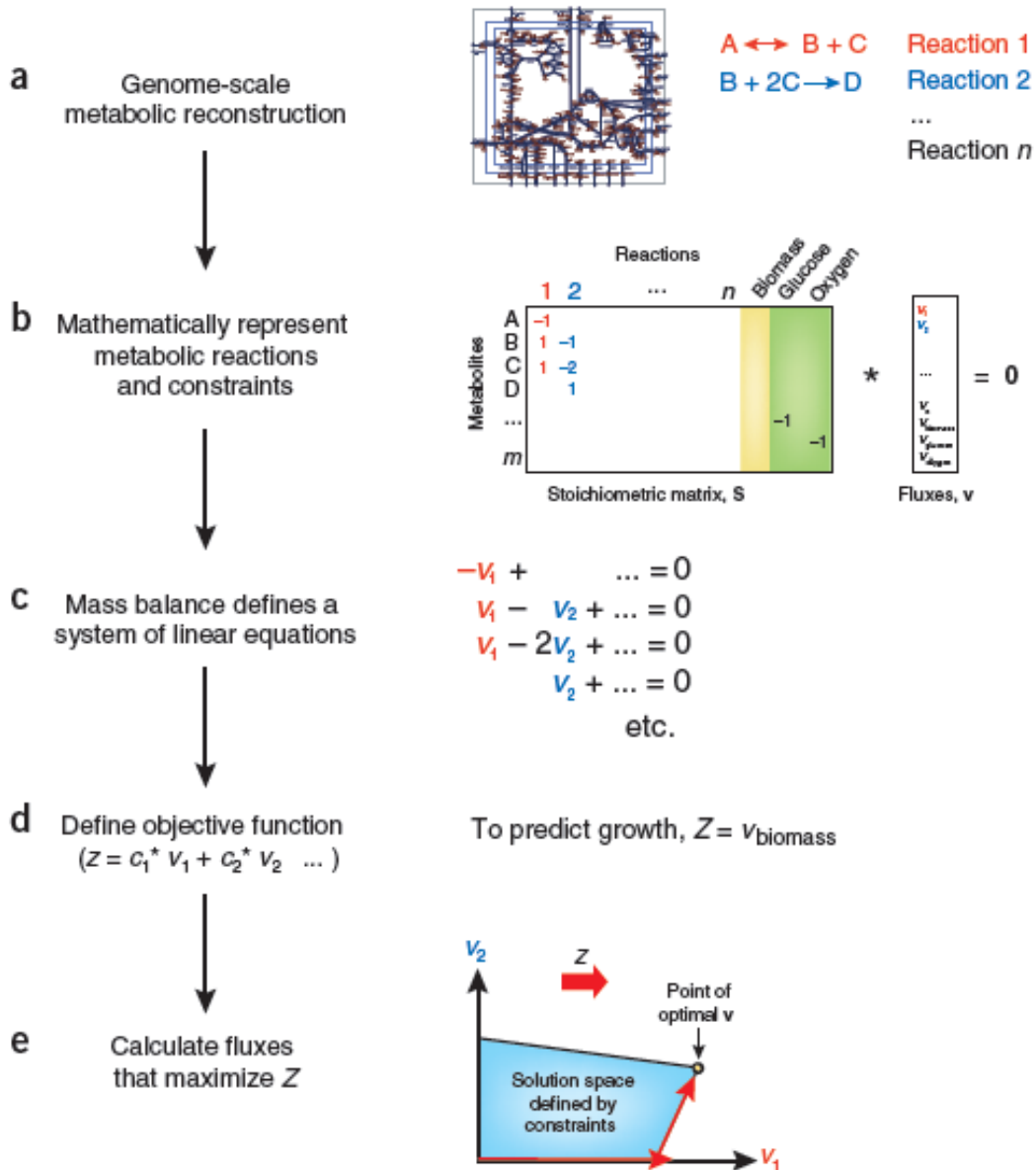

Figure 18 - Flux Balance Analysis - Overall Approach (Orth et al, 2010)

2.3.2 - OPTKNOCK Algorithm

The OPTKNOCK algorithm is a bilevel programming algorithm (Figure 19), meaning it takes the cellular objective function (as described in the previous flux balance analysis section) and then runs it while also maximizing a surrounding bioengineering objective (through the reaction knockouts) (Burgard et al, 2003).

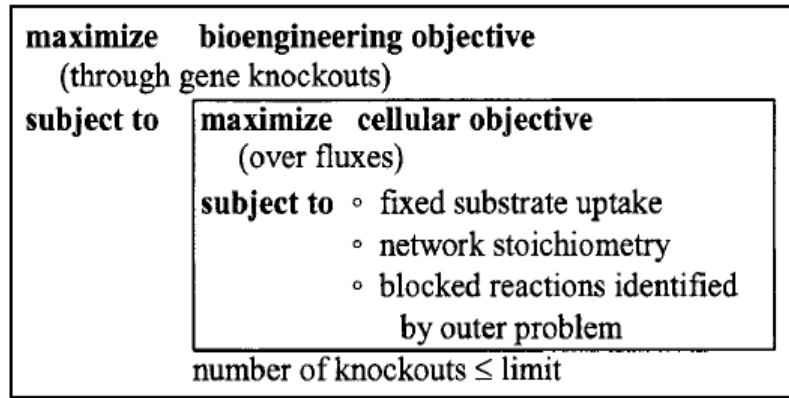

Figure 19 - OPTKNOCK algorithm framework (Burgard et al, 2003)

Below is the $Sv=0$ function (the stoichiometric matrix multiplied by the flux vector at steady state, as discussed in the section regarding FBA) rewritten within context of maximizing flux towards the cellular objective (that is, the target pathway).

N

M_{irrev}

M_{sec_only}

M_{rev}

Next one accounts for gene deletion/reaction elimination; this constraint ensures reaction flux is zero only if the y_j is zero, i.e., reaction is knocked out .

M

The next step is combination of the reaction knockout and objective function into the bilevel programming framework as illustrated in Figure 19. In other words, for every reaction knockout the algorithm is also maximizing the cellular objective function. Figure 20 shows the bilevel programming framework with the relevant equations plugged in.

$$\begin{array}{ll}
 \text{maximize} & v_{chemical} \\
 y_j & \\
 \text{subject to} & \text{maximize } v_{biomass} \\
 & v_j \\
 & \text{subject to } \left[\begin{array}{l}
 \sum_{j=1}^M S_{ij} v_j = 0, \\
 v_{pts} + v_{glk} = v_{glc_uptake} \\
 v_{atp} \geq v_{atp_main} \\
 v_{biomass} \geq v_{biomass}^{target} \\
 v_j^{\min} \cdot y_j \leq v_j \leq v_j^{\max} \cdot y_j, \quad \forall j \in \mathcal{M}
 \end{array} \right] \\
 & y_j = \{0, 1\}, \quad \forall j \in \mathcal{M} \\
 & \sum_i (1 - y_j) \leq K
 \end{array}
 \quad \begin{array}{l}
 \text{(OptKnock)} \\
 \text{(Primal)}
 \end{array}$$

Figure 20 - Bilevel programming framework - maximizing cellular and bioengineering objectives (Burgard et al, 2003)

This is where we apply linear programming to find the solution (i.e., the knockout which results in the highest flux redirected towards our target reactions). There is a rule in linear programming where for every linear programming problem (primal), there exists a unique optimization problem (dual) whose optimal objective value is equal to that of the primal problem.

The dual problem associated with the OPTKNOCK inner problem is as follows.

Note that both the primal and dual problems are bounded by constraints in the form of reaction knockouts, stoichiometric coefficients, and glucose uptake inputs. When bounded by these constraints the primal and dual problems are equal to each other at the optimal point. They can then be rewritten in order to solve for that optimum, which corresponds to our solution (i.e., the knockout which results in the highest flux redirected towards our target reactions).

2.4 - Formal Model Interface Design for Systems Integration

Now that the details for the semi-formal and formal modeling are in place, the next issue to consider is interface design for the systems integration of models from metabolic simulation and design space exploration.

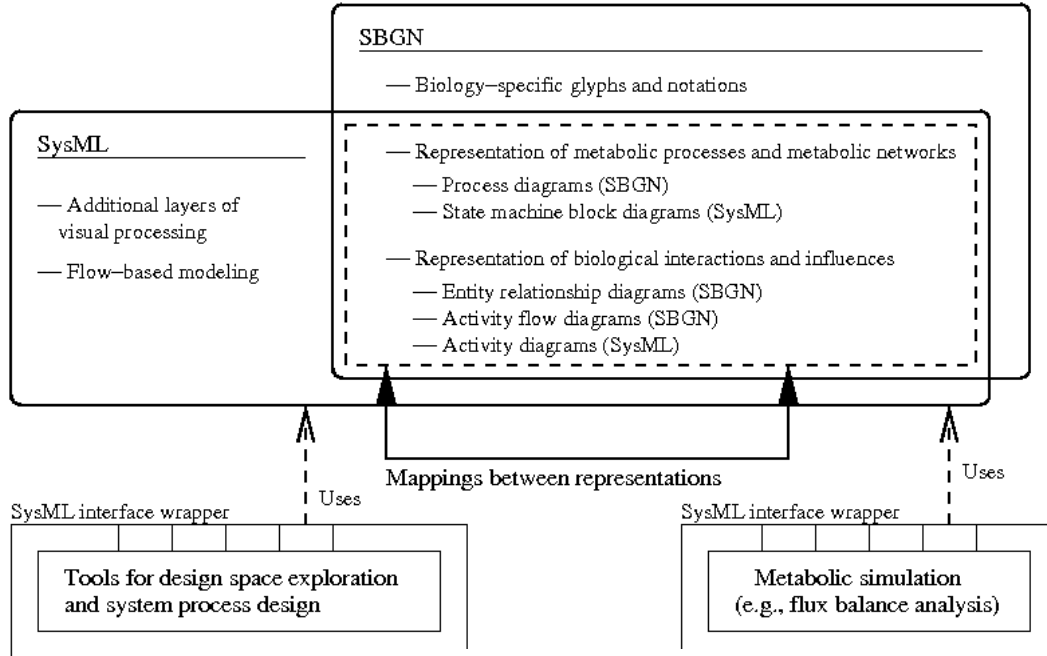

Figure 21 – Venn Diagram showing common and distinct features of SysML and SBGN, together with a framework for wrapping formal models with SysML interface constructs (e.g., ports).

The upper-half of Figure 19 is a Venn diagram of the relationship between SysML and SBGN. Although the formalisms for both visualizations have been designed to serve the needs of distinct communities, most of the distinctions are at the syntax level. There is, in fact, a surprising overlap in features common to both representations. The notable differences crop up in the visual representation of biology-specific glyphs and flow-based modeling. The three SBGN diagrams (process diagrams, entity relationships diagrams, and activity flow diagrams) are oriented respectively towards representing temporal/mechanistic aspects of biochemical processes (e.g., metabolism), signaling interactions between multistate entities (e.g., hormonal cascades), and biological

influences (e.g., gene regulation). Process diagrams correspond in SysML notation to structural constructs such as block diagrams, internal block diagrams, constrained block diagrams and to some extent behavioral constructs such as state machine diagrams. Entity relationship and activity flow diagrams correspond in the SysML notations to behavioral constructs such as activity diagrams.

The defining characteristic of SBGN is its customization and use of visual constructs for communication of ideas in biology. This is a good thing. Our supposition is that SBGN can be combined with SysML, resulting in a system representation that communicates ideas and acts as an interface to models for flow-based modeling (e.g., metabolic flux analysis and design explorations enabled through the use of OPTKNOCK).

Chapter 3 – Metabolic Engineering Experiment

3.1 – Background

3.1.1 – Semi-formal Model Design - Goals

The second purpose of this paper is to demonstrate the effectiveness of the framework discussed in Chapter 2, through application to a metabolic engineering experiment.

This process begins with the semi-formal model design portion of our framework (see the upper half of Figure 5) and the formulation of experimental goals/scenarios, followed by the generation of requirements. Accordingly, the objective of this experiment is to determine which reaction knockouts will maximize production of the metabolite artemisinin in our genetically engineered strain of yeast. The performance requirement is to maximize production of artemisinin. The functional requirement is to maximize production subject to the constraint of maintaining homeostasis.

The experimental procedure will determine the reaction knockouts using the OPTKNOCK algorithm, and verify the predicted results using flux balance analysis (FBA) simulations. Finally, we will present the results in visual form using a combination of ad hoc metabolic engineering diagrams, SBGN, and SysML.

3.1.2- Motivation and History

Malaria is an infectious disease which affects nearly 200-250 million people and kills nearly 700,000-1,000,000 people annually (*World malaria report 2010*). The majority of those who die from infection live in poverty and cannot afford access to the current anti-malarial drug standard, artemisinin. Consequently, any scientific advances

which can help lower the cost of artemisinin will translate into greater accessibility to the drug worldwide. There have been two such major scientific advances in the past five years. The first involves the reengineering of yeast to manufacture artemisinic acid, a precursor to artemisinin (Ro et al, 2006), and the second, the creation of an alternative “dihydro” pathway within yeast which enables synthesis of artemisinin *in situ* in the presence of activated oxygen (Zhang et al, 2008).

3.1.3 – Advance 1: CYP71AV1/CPR Pathway

The high cost of Artemisinin stems from the extraction process of the drug from the herb *Artemisia annua* (*A. annua*). Researchers at UC-Berkeley (hereafter referred to as the Keasling group) have developed a procedure to cut the costs of drug development by genetically engineering *S. cerevisiae* to produce artemisinic acid, a precursor to artemisinin (Ro et al, 2006). By sourcing the drug from microbes instead of plants, overall production time is decreased from months to days, and biomass fraction increases from 1.9% to 4.5%, resulting in nearly two orders of magnitude of productivity improvement.

The Keasling group’s strategy for producing artemisinin in *S. cerevisiae* consists of three major steps:

1. Increase farnesyl pyrophosphate (FPP) production. As illustrated in Figure 22, this was done by upregulating the expression of tHMGR and ERG20, and downregulating the expression of ERG 1-8, 11-13, 24-25.

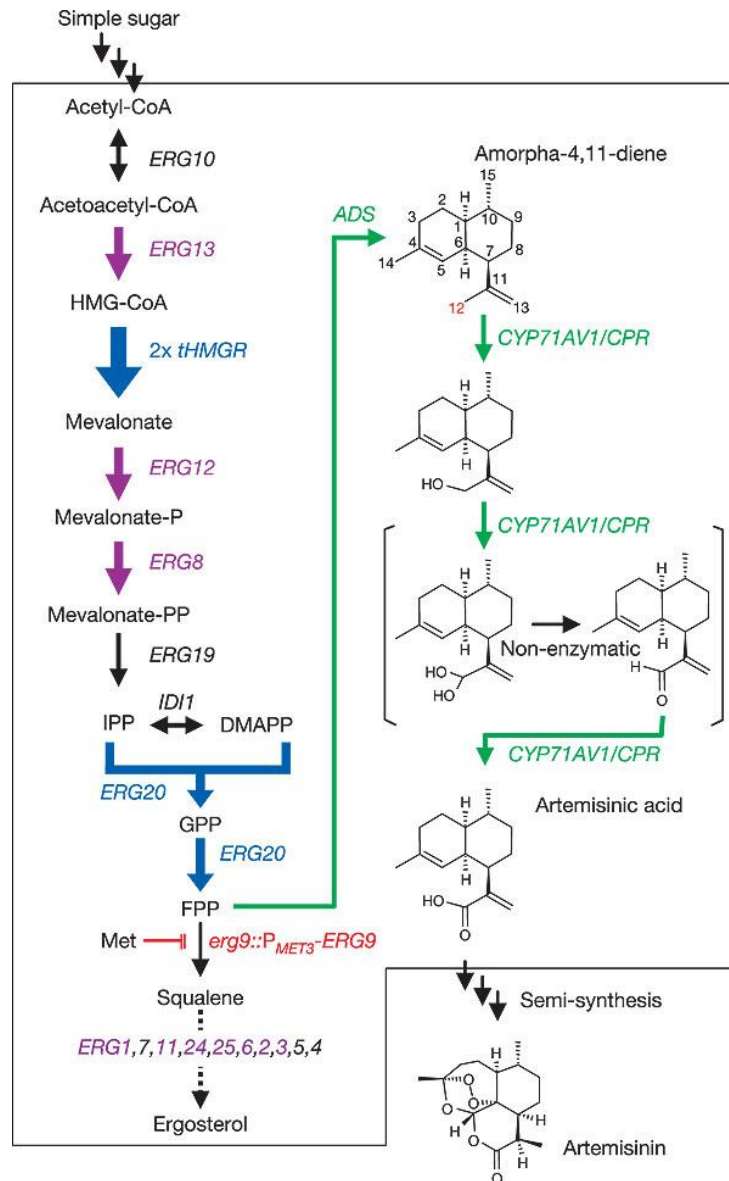

Figure 22 - Schematic Representation of engineered artemisinin acid biosynthetic pathway in *S. cerevisiae* (Ro et al, 2006)

2. Introduce the amorphadiene synthase (ADS) gene into the genetic sequence of *S. cerevisiae* in order to convert FPP to amorphadiene. To drive carbon towards the inserted ADS pathway, the Keasling group uses a methionine-repressible promoter to downregulate ERG9, the gene which expresses the

enzyme squalene synthase (red), and catalyzes the next step in the mevalonate pathway in wild type yeast.

3. Insert genes CYP71AV1 and CPR from *A. Annua* to express enzymes from the family cytochrome P450. These enzymes catalyze the oxidation of amorphadiene to artemisinic acid.

3.1.4 – Advance 2: DBR2 Pathway

A second group of researchers from the Canadian Plant Biotechnology Institute (hereafter referred to as the Covello group), have determined that the gene DBR2, a complementary DNA clone isolated from the flower buds of *A. annua*, corresponds to artemisinic aldehyde double bond reductase activity in *A. annua*. As illustrated in the highlighted portion of Figure 23, when *S. cerevisiae* uptakes the DBR2 gene, it creates a new metabolic pathway from artemisinic alcohol to dihydroartemisinic acid (*Zhang et al, 2008*).

In this pathway, artemisinic alcohol is converted to dihydroartemisinic alcohol through the action of the double bond reductase enzyme, as regulated by the DBR2 gene. The double bond reductase eliminates the nonring double bond in artemisinic alcohol by adding two atoms, resulting in the nickname “dihydro” pathway. While the researchers were unable to identify what specific enzymes controlled for the continued oxidization of dihydroartemisinic alcohol to dihydroartemisinic acid, oxidation did take place, just as artemisinic alcohol oxidized to artemisinic acid in three steps.

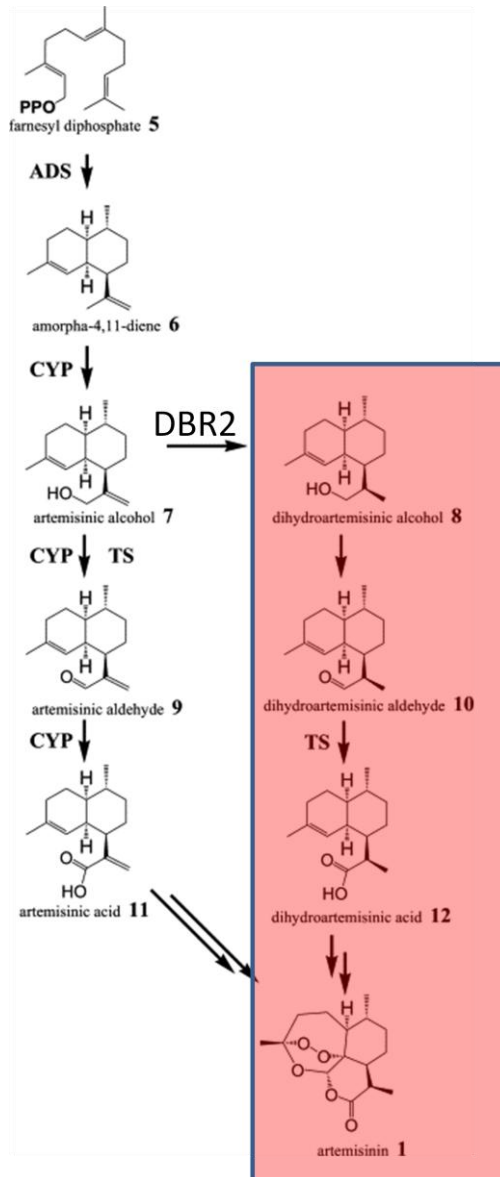

Figure 23 - Covelto Group Pathway (Source: Zhang et al, 2008)

A key benefit of dihydroartemisinic acid is that it quickly converts to artemisinin in the presence of activated oxygen. Artemisinic acid, on the other hand, requires two additional steps in order to isolate artemisinin. In other words, this means that in a scale-up facility, a researcher can simply run an oxygenating hose through a bioreactor and produce artemisinin *in situ*, thereby avoiding the need for time-consuming extraction steps. This lowers the overall cost (Acton et al, 1992).

It is important to note that the new strains of yeast developed by the Covello group contain both the “dihydro” pathway and Keasling Group pathways. While the “dihydro” pathway presents productivity and economic advantages, the enzymes that catalyze the formation of artemisinic acid from artemisinic alcohol play important roles upstream within the overall yeast metabolic network. The creation of a new “dihydro” only strain of yeast requires validation and verification to ensure that knockouts forcing carbon to the “dihydro” route do not affect the performance of the overall metabolic network.

3.2 - Formal Models for Metabolic Engineering

For the formal model sections of our multi-level framework, design space exploration takes the form of determining which reaction knockouts will maximize production of artemisinin. To do this, we run a mathematical abstraction of a yeast model (as described earlier in Chapter 2) through the OPTKNOCK Algorithm. Then, with the OPTKNOCK results in hand, the next step is to verify those results using flux balance analysis (FBA) simulation. The latter coincides with the formal model analysis portion of our framework.

3.2.1 - Tools

The simulation and design space exploration elements of the *in silico* experiment employ MATLAB 7.11.0, a Tomlab/Cplex or Gurobi Linear Programming solver, the COBRA Toolbox for MATLAB, and a suitable yeast model.

MATLAB 7.11.0 is a software package, which after more than two decades of development, has become one of the standards for numerical analysis in the greater scientific community. CPLEX is a linear programming solver designed by IBM. The

Tomlab plugin allows a MATLAB user to run CPLEX from within MATLAB. Gurobi is an alternative linear programming solver free for academic users that runs within MATLAB. The COBRA (Constraint Based Reconstruction and Analysis) Toolbox is a package for MATLAB designed for *in silico* analysis of biological models. (Becker et al,2007; Hyduke et al 2011). I will discuss yeast models further on in Section 3.2.4.

3.2.2 - Methodology

Figure 24 provides a high level view of the procedure for design space exploration and simulation processes in the *in silico* experiment. The experimental procedure consists of the following steps:

1. Prepare a SBML and COBRA compatible model of *S. cerevisiae* so that it accurately reflects the genotypes of the strains in possession and load the model into the COBRA Toolbox.
2. Set parameters and constraints of the simulated environment. This involves:
 - a. Define the media and nutrients available to the microbial culture;
 - b. Remove reactions from consideration that would be difficult or unreasonable to knockout;
 - c. Establish the target reaction to maximize flux towards (for our purposes, the artemisinin production biosynthetic pathway);
 - d. Declare biomass formation to be the constraint reaction;
3. With the aforementioned parameters and constraints in place, run the OPTKNOCK algorithm. OPTKNOCK will output a list of suggested reactions to knockout.

Design Space Exploration / Experimental Prediction

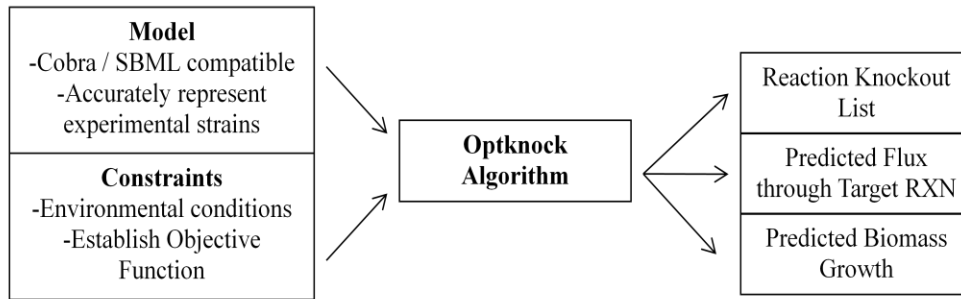

Simulation / Validation and Verification

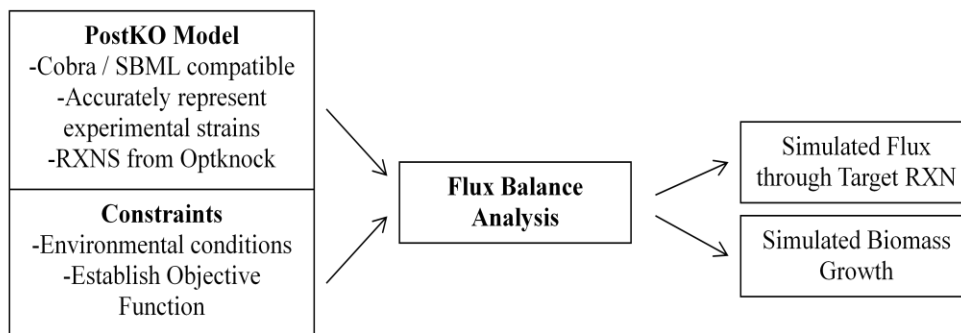
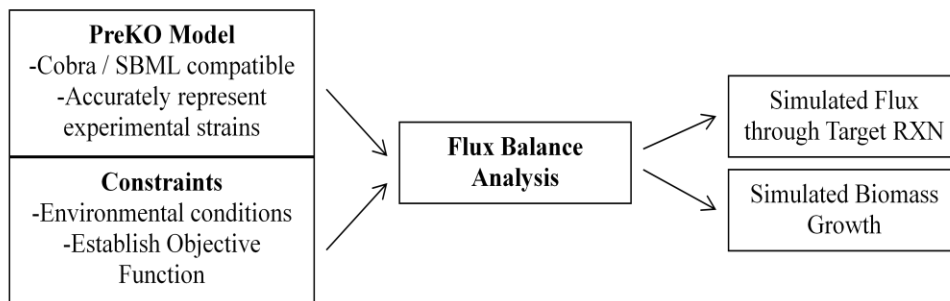

Assessment

Check 1: Compare Optknock Prediction with Post KO Model FBA Result – Fluxes should match

Check 2: Compare PreKO Model FBA Result with Post KO Model FBA Result – Fluxes through target reaction should increase

Figure 24 - Schematic of a Computational Metabolic Engineering Experiment

4. Run a flux balance analysis simulation on the preknockout model. The preknockout model is the same model that was run through the OPTKNOCK algorithm. Flux balance analysis will output simulated flux through target reaction and simulated biomass growth.
5. Modify the preknockout yeast model to exclude the reaction knockout list as output by the OPTKNOCK algorithm. This is the postknockout yeast model.
6. Run a flux balance analysis simulation on the post knockout yeast model to obtain post knockout results. Flux balance analysis will output simulated flux through target reaction and simulated biomass growth.
7. Verify the results of the simulation. For Step 7, there are two indicators that the algorithm worked: (1) The simulated maximum flux through the target reaction should correspond with OPTKNOCK's prediction, and (2) The maximum flux should increase through the target pathway going from the Preknockout model to the Postknockout model.

Step 3 of this procedure (OPTKNOCK) corresponds to the design space exploration quadrant of the systems engineering framework. Step 4 of this procedure (Flux Balance Analysis) corresponds to the simulation quadrant of the systems engineering framework.

3.2.3 - Preparing the Model

The most current curated model of yeast is referred to as the *Yeast Consensus Model*, available at: <http://www.comp-sys-bio.org/yeastnet/> (Herrgard et al, 2008). While it would have been the ideal model to use as the basis for the simulation experiment, we found that the *Yeast Consensus Model* is neither SBML (systems

biology markup language) nor COBRA compliant. Furthermore, although the protocol behind SBML compliance can be extensive in its own right, a general overview of what compatibility entails will suffice here (*Hucka et al, 2003*).

Within the model, there are two categories of classes: (1) reaction classes and (2) metabolite classes. To be SBML compatible, each reaction class must have attributes that include the abbreviation for the reaction, the name(s) of the compounds in the reaction, the equation of the reaction, the cellular compartment in which the reaction takes place (e.g., cytosol, mitochondria, ribosomes, etc), and the direction of the reaction (i.e., irreversible, reversible). In order for the model to be COBRA compatible, each reaction must also have a lower and upper bound with respect to flux for each direction of the reaction, along with an objective function status (either 0 or 1). For metabolite classes, SBML compatibility entails including attributes for a compound's abbreviation, name, and formula. COBRA compatibility requires the attribute of compound charge. It is important to note that while additional attributes could be included within classes, such as EC (enzyme class) numbers, KEGG (Kyoto Encyclopedia of Genes and Genomes) abbreviations, and molecular weights, they are not necessary for SBML/COBRA compatibility. Of all the attributes listed above, the most important for the purposes of the simulation experiment is the equation, as the mathematical abstraction of the *S. cerevisiae* model will be based on this attribute. A practical caveat - because the equation is dependent on the compound abbreviations and direction of reaction, it is important to verify that both of these attributes also correspond correctly with the equations.

Since the consensus yeast model was neither SBML nor COBRA compatible,

the next best choice was the iMM904 model (note that i stands for *in silico*, MM are the initials of Monica Mo, who developed the model, and 904 is the number of genes in the model) (Mo et al, 2009). The iMM904 model corresponds to the genetic makeup of the wild type yeast strain S288C.

The yeast strains used in the Sriram lab are derivatives of yeast strain W303 from the Covello group, which has some differences from S288C with respect to genetic makeup that have to be accounted for in the model:

S288C has the genotype: *MAT α SUC2 gal2 mal mel flo1 flo8-1 hap1 ho bio1 bio6* (Mortimer et al, 1986)

W303 has the genotype: *MAT α /MAT α {leu2-3,112 trp1-1 can1-100 ura3-1 ade2-1 his3-11,15}* (Thomas et al, 1989)

When observing genotypes, it is important to note that capitalized letters are working versions of the gene, and lower case letters are nonfunctional. Nonfunctional genes can be restored to functional status when the cell uptakes a plasmid with the gene.

The following plasmids were taken up by the W303 genotype to generate the Sriram lab's strains: (Zhang et al, 2008)

Strain 1: *pESC-HIS, pESC-LEU, pYES-DEST52-GUS2*

Strain 2: *pESC-HIS-FPS-ADS, pESC-LEU-CYP-CPR, pYES-DEST52-GUS.*

Strain 3: *pESC-HIS-FPS-ADS, pESC-LEU-CYP-CPR, pYES-DEST52-DBR2*

Each plasmid contained its own strain-dependent combination of pathways. Being a control, Strain 1 received a control plasmid which reactivated histidine, reactivated leucine, and contained a placeholder gene DEST52-GUS. Strain 2 contained the artemisinic acid production pathway which consists of the ADS genes and the CYP-CPR genes (refer Figure 22) along with the DEST52-GUS gene. Strain 3 contained the genes coding for the artemisinic acid pathway and the dihydroartemisinic pathway (attached with the DEST-52 gene).

For the purposes of modifying the model, this means that between S288C and W303, only the SUC2 gene and corresponding reaction need to be removed, as the rest of the genes are nonfunctional. An additional point to note is that the active versions of his, leu and ura3-52 in the model represent the yeast strain taking up the plasmids containing HIS, LEU, and DEST52. By taking up the plasmids, the yeast cell restores the ability to synthesize histidine, leucine, and uracil. After accounting for all of the aforementioned factors in the W303 strain, this leaves the genes trp1, ade2, and can1-100. Any reactions controlled by active versions of these genes would have to be removed from the model in order to reflect the experimental strain. Table 3 contains a summary of all reactions removed from the iMM904 model. It coincides with Strain 1.

Table 3 - Preparing the Yeast model – Strain 1

**REMOVALS
(STRAIN 1)**

Gene	RXN	RXN Description
SUC2	DGGH	alpha-D-glucoside glucohydase
trp1	PRAIi	phosphoribosylanthranilate isomerase (irreversible)
ade2	AIRCr	phosphoribosylaminoimidazole carboxylase
can1-100	ARGt2r	L-arginine reversible transport via proton symport

When adding reactions to the model, it helps to reexamine the plasmids taken up by the strains. Every one of the capitalized genes, except for the promoters (pESC and pYES) will have to be accounted for in the strain reactions.

As a case in point, Strain 1 took up the pESC-HIS, pESC-LEU, pYES-DEST52-GUS2 plasmids. HIS, LEU, and DEST52 are already present in the model and GUS2 regulates the expression of the enzyme beta-glucuronidase. However, none of the reactants for the reactions that beta-glucuronidase controls were present in the model as metabolites, meaning that this enzyme would be essentially inactive, and therefore not required in the model. This is why DEST52-GUS 52 is referred to as a placeholder earlier (as it is simply there as a control until it functions as a delivery vehicle for DBR2 in strain 3).

Strain 2 took up the plasmids pESC-HIS-FPS-ADS, pESC-LEU-CYP-CPR, pYES-DEST52-GUS2. HIS, LEU, and DEST52 are already present in the model. Referring back to Figure 22 , one will remember that the FPS-ADS gene controls the conversion of FPP to amorphadiene, and that CYP/CPR controls the 3 step oxidation of artemisinic alcohol to artemisinic acid. While Strain 2 represents the Keasling group's pathway in the simulation experiment, it is important to remember that the W303 strain is still genetically different overall from the Keasling group's strain, BY4742. Thus, a true direct comparison between the Keasling group's results and this experiment may not be possible. In order to represent the genotype of strain 2, the reactions in Table 4 were added to the model for strain 1 (Table 3).

Table 4 - Preparing the Yeast model - Strain 2

ADDITIONS (STRAIN 2)		
(in addition to strain 1 removals)		
Gene	RXN	RXN Description
FPS-ADS	ADS	Amorpha-4,11-diene synthase
CYP-CPR	ARTALC_CYP7	amorph-4,11-diene to artemisinic alcohol
CYP-CPR	ARTALD_CYP7	artemisinic alcohol to artemisinic aldehyde
CYP-CPR	ARTACID	artemisinic aldehyde to artemisinic acid

Strain 3 took up the plasmids pESC-HIS-FPS-ADS, pESC-LEU-CYP-CPR, and pYES-DEST52-DBR2 plasmids. Referring to Figure 23, one will remember that the DBR2 gene controls for the conversion of artemisinic alcohol to dihydroartemisinic alcohol, i.e., the “dihydro” pathway. Strain 3 essentially represents the Covello group’s strain in the simulation experiment, which included both the Keasling group’s pathway and the “dihydro” pathway. The reactions listed in Table 5 were added to the strain 2 model (see Table 3 and Table 4) to accurately represent the strain 3 genotype.

Table 5 - Preparing the Yeast Model - Strain 3

ADDITIONS (STRAIN 3)		
Gene	RXN	RXN Description
DBR2	DBR2	artemisinic aldehyde to dihydroartemisinic aldehyde
DBR2	DARTACID	dihydroartemisinic aldehyde to dihydroartemisinic acid

3.2.4 - Setting Parameters and Constraints

Preparation of the simulation environment begins with the setting of parameters and constraints for the availability of amino acids and nutrients from the media (*Becker et al, 2007; Hyduke et al, 2011*). Since the laboratory media is galactose based, the simulation set galactose uptake to $11.1 \mu\text{mol}\cdot\text{gDW}^{-1}\cdot\text{h}^{-1}$. And since the W303 derived

strains lack capability to produce adenine and tryptophan, those two nutrients would have to be present within the media, or else there would be no flux. Uptake for these two nutrients was set to $0.01087 \mu\text{mol}\cdot\text{gDW}^{-1}\cdot \text{h}^{-1}$ and $0.009803 \mu\text{mol}\cdot\text{gDW}^{-1}\cdot \text{h}^{-1}$. For additional details regarding the media makeup, please consult the MATLAB code in Appendix A.

When choosing reactions to remove from further consideration in the design (i.e., knockout), the simulation essentially picked biomass, reactions involving ATP synthase, exchange and transport reactions, reactions not linked to genes, dead end reactions (i.e., zero flux) and the stated target reaction. The omission of the target reaction and biomass in reactions for potential knockout is intuitive. Exchange, transport, and non-gene linked reactions were not included as they tend to be harder to knockout through genetic engineering. Reactions involving ATP synthase are crucial for cell homeostasis, and thus necessary towards meeting our functional requirement of making sure the cell does not die (*Feist et al, 2010*).

The target reactions for maximization of flux varied with each strain, and are summarized in Table 6. For Strain 1, the target reaction was designed to maximize flux towards the reaction which produces FPP (the reactant which converts to amorphadiene in the presence of the enzyme controlled by the gene ADS), referred to in the model as GRTT. For Strain 2, the target reaction was the reaction to form artemisinic acid, referred to in the model as ARTACID. For Strain 3, the target reaction was the reaction to form dihydroartemisinic acid, referred to in the model as DARTACID.

Table 6 - List of Target Reactions

Strain	RXN	RXN Description	RXN Equation	RXN Compartment
1	GRTT	Geranyl-transtransferase	$\text{grdp}[\text{c}] + \text{ipdp}[\text{c}] \rightarrow \text{frdp}[\text{c}] + \text{ppi}[\text{c}]$	Sterol Metabolism
2	ARTACID	artemisinic aldehyde to artemisinic acid	$\text{artCHO}[\text{c}] + \text{nadph}[\text{c}] \rightleftharpoons \text{artCOOH}[\text{c}]$	Artemisinin Pathway
3	DARTACID	dihydroartemisinic aldehyde to dihydroartemisinic acid	$\text{dhartCHO}[\text{c}] + \text{nadp}[\text{c}] + \text{h}_2\text{o}[\text{c}] \rightleftharpoons \text{dhartCOO}[\text{c}] + \text{nadph}[\text{c}] + 2 \text{h}[\text{c}]$	Dihydro Artemisinin Pathway

3.2.5 - OPTKNOCK Results and FBA Verification

Table 7 is a summary of the results of the metabolic engineering experiment.

Table 7 - OPTKNOCK Results and Verification (Units: $\mu\text{mol}\cdot\text{gDW}^{-1}\cdot\text{h}^{-1}$)

STRAIN 1			Growth Rate of Yeast Cells		Targeted RXN = GRTT	
Trial #	Suggested KO	Optknock Prediction	PreKO Biomass	PostKO Biomass	PreKO Max Flux	PostKO Max Flux
1	HICITDm	2.5098	0.1098	0.057	2.4393	2.5209
2	HACNHm / UGLT	2.5098	0.1098	0.057	2.4393	2.5209
3	ADK1 / SACCD1 / G6PDH2	2.5098	0.1098	0.057	2.4393	2.5209
STRAIN 2			Growth Rate of Yeast Cells		Targeted RXN = ARTACID	
Trial #	Suggested KO	Optknock Prediction	PreKO Biomass	PostKO Biomass	PreKO Max Flux	PostKO Max Flux
1	HACNHm	2.593	0.1098	0.057	2.5199	2.6045
2	ACONT / HICITDm	2.593	0.1098	0.057	2.5199	2.6045
3	SACCD2	2.593	0.1098	0.057	2.5199	2.6045
STRAIN 3			Growth Rate of Yeast Cells		Targeted RXN = DARTACID	
Trial #	Suggested KO	Optknock Prediction	PreKO Biomass	PostKO Biomass	PreKO Max Flux	PostKO Max Flux
1	SACCD2	2.558	0.1098	0.057	2.4859	2.5694
2	ADK1 / SACCD2	2.558	0.1098	0.057	2.4859	2.5694
3	HICITDm / ILETA	2.558	0.1098	0.057	2.4859	2.5692

And Figure 25 is a graphical representative of the pre and post knockout fluxes for each strain.

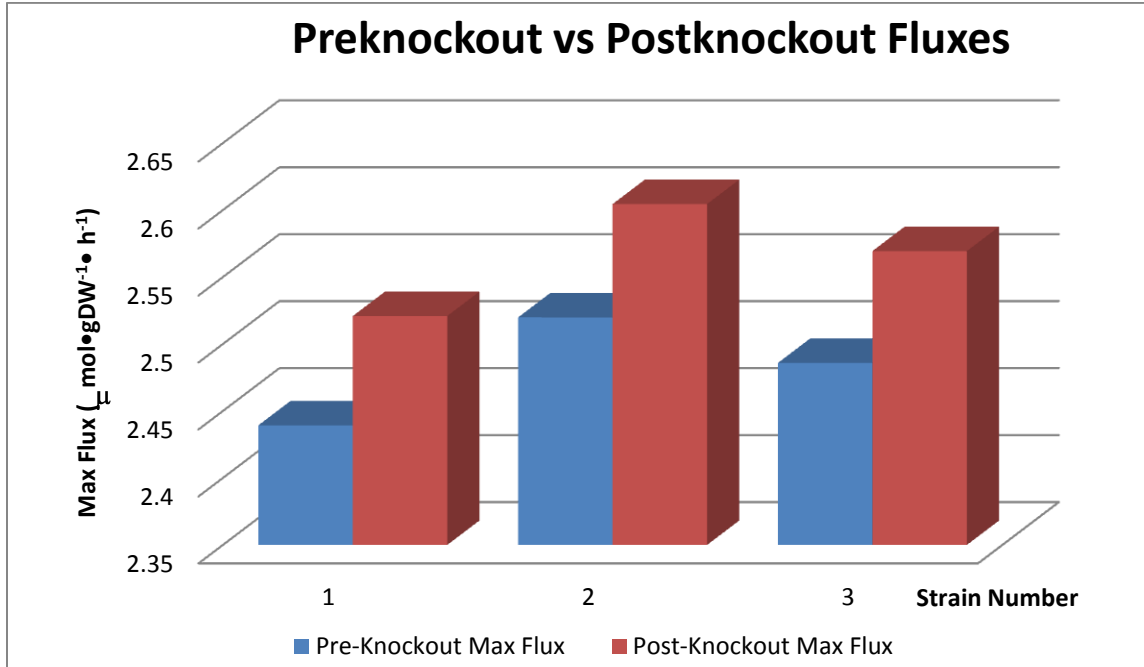

Figure 25 - A Bar Graph Comparing Pre and Post Knockout fluxes for each strain

As indicated in Figure 24, validation corresponds to a two check procedure: (1) Agreement between the OPTKNOCK prediction and the FBA PostKO Max Flux simulation, and (2) An increase in maximum flux through the targeted reaction. It is important to remember that our functional requirement is to maintain homeostasis within the cell. As long as the growth rate of biomass is greater than 0.0, then we will have met the functional requirement.

The OPTKNOCK predictions and post knockout FBA max flux simulation through the target reaction agree, as they are always within 0.012 µmol·gDW⁻¹·h⁻¹ of each other.

A comparison of the preKO and postKO max fluxes through the target pathway always showed an increase of 0.080-0.085 $\mu\text{mol}\cdot\text{gDW}^{-1}\cdot\text{h}^{-1}$. When comparing pre and post knockout flux, it did not seem like this increase was particularly significant (with the change in flux between pre and post knockout models being less than 0.1). We would not anticipate results this small would show up experimentally.

There is, however, a trend within these results, which will become more apparent with visualization. SACCD1, SACCD2, HACNHm, and HICITDm are all suggested knockouts that lie in the same pathway of lysine formation, the latter stemming from the combination of alpha keto glutarate and acetyl CoA (refer Figure 26). One can logically hypothesize that knocking out reactions in this pathway would cause a buildup of acetyl CoA. This strategy is supported by Figure 22 and Figure 23, where one can see that acetyl CoA is the primary metabolite feeding into the mevalonate pathway, the site of our inserted genetically engineered pathways. Thus, an increase in acetyl CoA could feasibly translate into an increase in flux through our target pathways. From this perspective, the suggested knockouts make sense. Rather than having to produce its own lysine, the cell could obtain the amino acid lysine from the medium. In fact, it is possible that experimenting with the makeup of the media may result in higher and more significant changes in flux when comparing the pre and post knock out models.

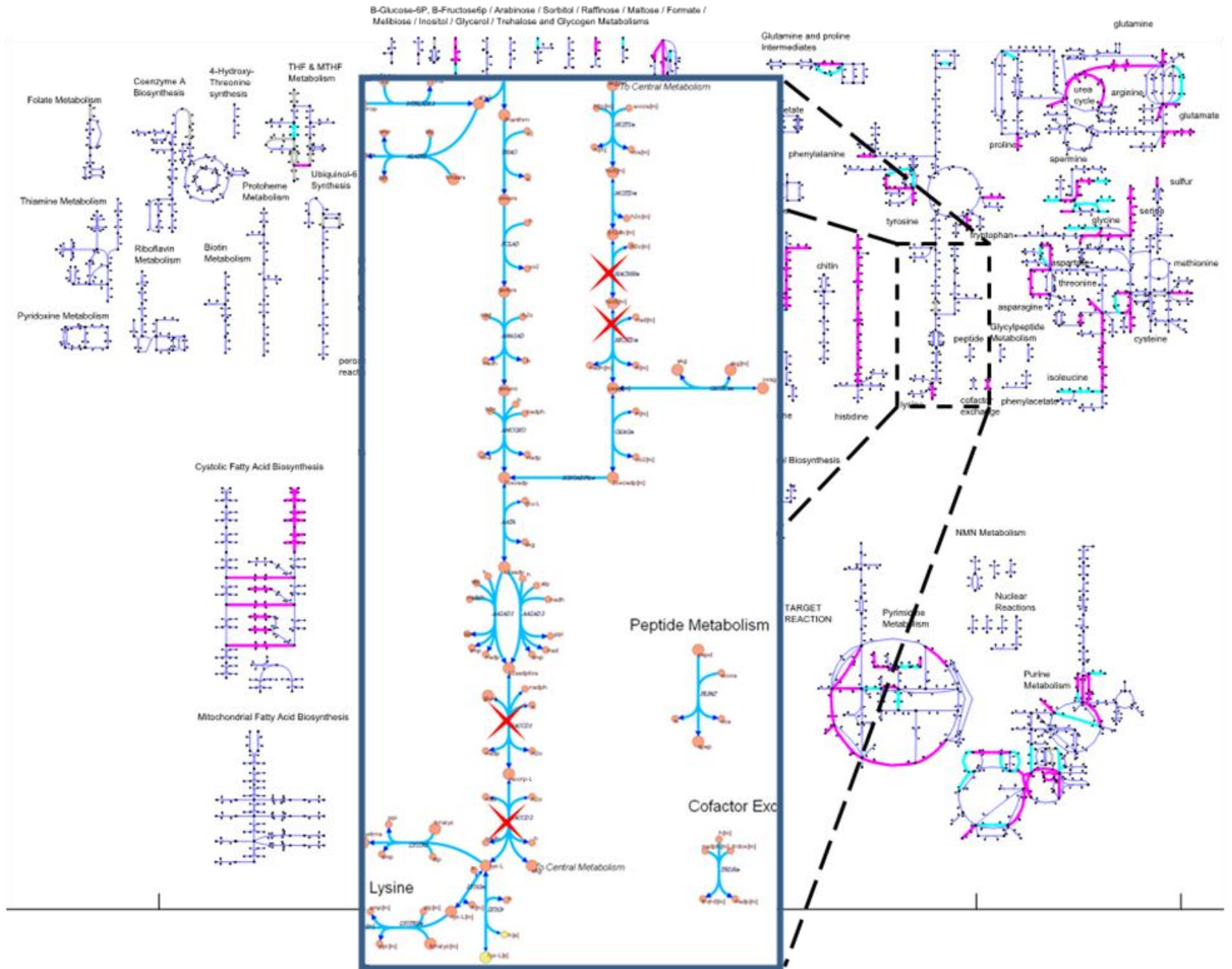

Figure 26 - Lysine Metabolic Pathway

3.3 – Semi-Formal Models for Metabolic Engineering

The purpose of this section is to compare and contrast the strengths and weaknesses of the three types of abstraction (ad-hoc, SBGN, and SysML) for visualization of experimental results.

Two key concepts associated with visualization are information hiding and encapsulation. With respect to the experiment, information hiding refers to the omission of all irrelevant pathways of interest, and encapsulation refers to the grouping of sets of reactions by their pathways. From the perspective of designing an efficient metabolic process, the most relevant pathways are: (1) The mevalonate pathway (on which our target reactions were inserted), (2) Glycolysis / the TCA cycle (on which a key metabolite, acetyl CoA, is produced), and (3) The pathway of lysine formation, which stems from the combination of alpha keto glutarate and acetyl CoA. These pathways are highlighted in Figure 27. Visualization techniques that draw attention towards these pathways, and eliminate information not needed for decision-making, will be helpful.

The first type of visualization, (see for example, Figure 27) employs an ad hoc notation for the visual display of yeast metabolism: use of this notation is state-of-the-art practice in the metabolic engineering field. This notation is ad hoc because it comes from a commercial toolbox and is not an industry standard. The ad hoc notation places an emphasis on showing *flux* and giving a *bird's eye view* of the metabolic system. The second type of visualization (see Figure 28) involves an SBGN compliant diagram based on a single knockout run of strain 2. Its emphasis is on showing the topological connections between the metabolites. The third type of visualization (see Figure 29 and Figure 30) is a set of two SysML compliant diagrams that show a single knockout run of

strain 2. Figure 29 is an internal block diagram that emphasizes the connectivity of the *reactions* through which the carbon atoms flow. Figure 30 is a parametric diagram that shows how flow can be modeled using constraints.

3.3.1 - Ad Hoc Abstraction

This section briefly discusses the key visual abstractions, and advantages and disadvantages of the ad hoc visualization (associated with the COBRA Toolbox).

Key Abstractions. The labeled segments act as abstractions, hiding information specific to nodes and encapsulating nodes on the same pathway together. Experienced Metabolic Engineers will have an intuitive understanding of the labeled pathways. Hence, they may not need to see individual nodes within a labeled segment in order to understand what is going on within the networks. Engineers without a metabolic engineering background may have difficulty understanding how the suggested knockout drives metabolic traffic towards Acetyl CoA and the artemisinic acid pathway.

Advantages. The primary purpose of this ad hoc diagram notation is to provide a bird's eye view of yeast metabolism. In Figure 27, each black node represents a compound, with each line between nodes representing a reaction. There are well over a thousand reactions represented here, so this type of diagram does a great job of showing how complex yeast metabolism is (with the pathways highlighted in yellow being our pathways of interest). The metabolic flux is represented via color and line thickness (in this case pink and blue show corresponding areas of high metabolic traffic). This type of representation can be useful in virtual space, since it allows for zooming in, zooming out, and creating external links to websites with information on each reaction / compound.

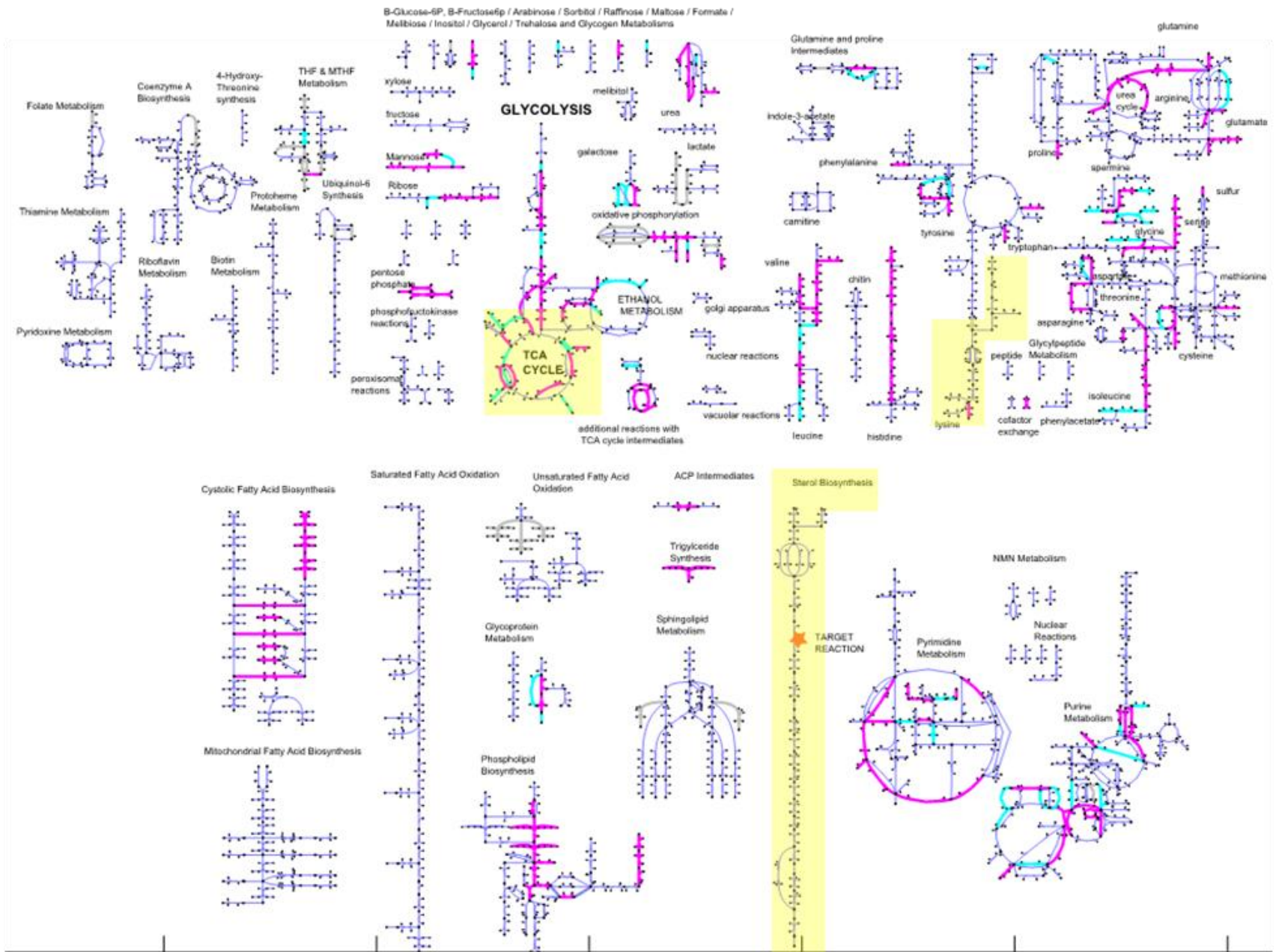

Figure 27 –A Non standard de facto Visual Abstraction generated using BIGG and the COBRA Toolbox (Hyduke et al, 2011))

Disadvantages. First, it is impossible to see what is going on at a more detailed level without zooming in. A second disadvantage is the lack of clarity in how the different pathways represented as segments connect to each other. This problem can be mitigated by representing flux with color and line thickness is an intuitive way to show metabolic traffic; however, this potential solution is not device independent. To summarize, generally speaking, the COBRA Toolbox is relatively limited in terms of its visualization capabilities. The text-based layout means that the visual layout is rigid, with only the colors and line thickness of metabolic traffic being capable of modification (Hyduke et al, 2011; Schellenberger et al, 2010).

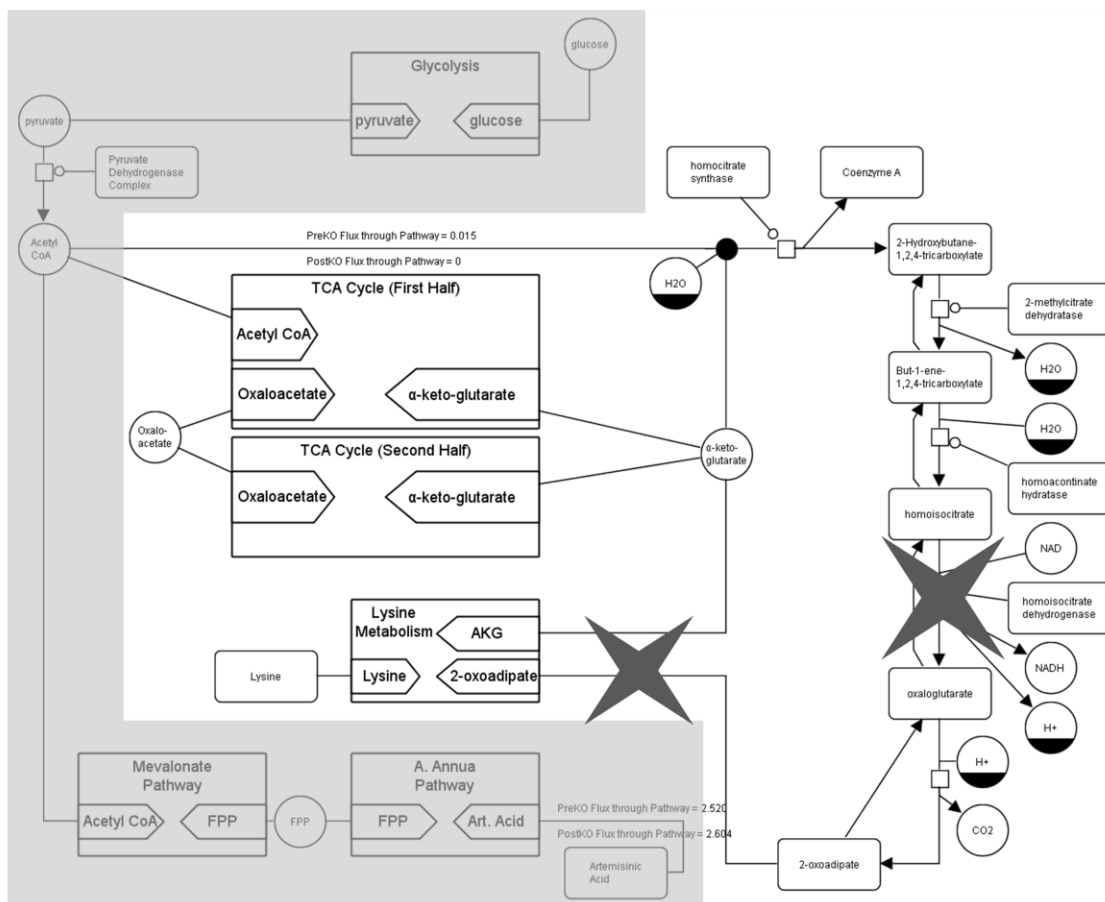

Figure 28 – SBGN compliant notation, generated using VANTED and SBGN-ED software (Junker et al, 2006; Czauderna et al, 2010). The target pathway for flux is highlighted and the suggested knockouts are crossed out.

3.3.2 - SBGN Abstraction

This section briefly discusses the key abstractions, and advantages and disadvantages of SBGN as a visual formalism.

Key Abstractions. The abstractions specific to SBGN and biology are as follows: simple molecules are represented by circles, with more complex compounds represented by rectangles with rounded corners. Repeated compounds are partially filled in. Reactions are represented by squares. Enzymes are marked by compounds linked to circles which modify the squares (See Figure 10 in Section 2.2.2 for the complete list of glyphs). The next important abstraction in SBGN is the subgraph. As illustrated in Figure 28, the subgraph is the functional equivalent of a black box in systems engineering and enables the user to condense a series of relevant reactions into a subgraph with links connecting the subgraph to other metabolites. Subgraphs are crucial abstractions as they enable encapsulation of a group of reactions in a pathway while hiding the details of each individual reaction, thereby freeing up space in the layout for the reactions of interest.

Advantages. SBGN diagrams provide a visual representation for how the suggested knockout reaction (conversion of but-1-ene-1,2,4-tricarboxylate to homoisocitrate as catalyzed by the enzyme homoaccontinate hydratase) drives traffic back towards Acetyl CoA, the key bottleneck. A second benefit stems from their use of biology-specific glyphs – that is, glyphs that allow for a quick understanding of the types of compounds present in a pathway.

Disadvantages. The main disadvantage of SBGN, at least with respect to the needs of the metabolic experiment, is lack of a formal methodology for modeling flow. Metabolic flux is the key parameter for determining activity in metabolic networks. As a quick

workaround and for the time being, we were able to annotate some flow values, but there will need to be a formal abstraction for flux in order to actually model parameters and constraints.

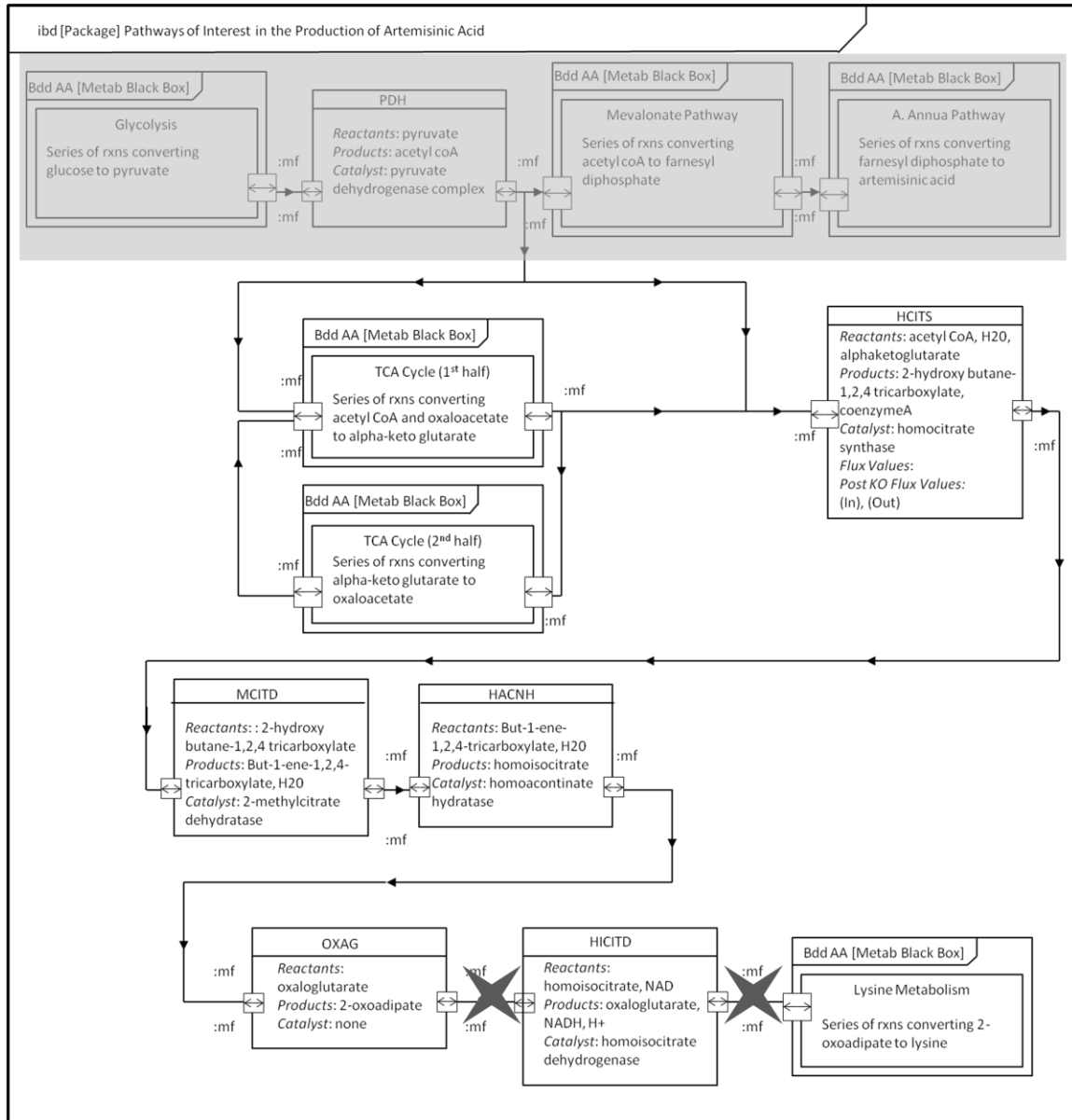

Figure 29 - SysML Visual Model for Pathways of Interest The target pathway for flux is highlighted and the suggested knockouts are crossed out.

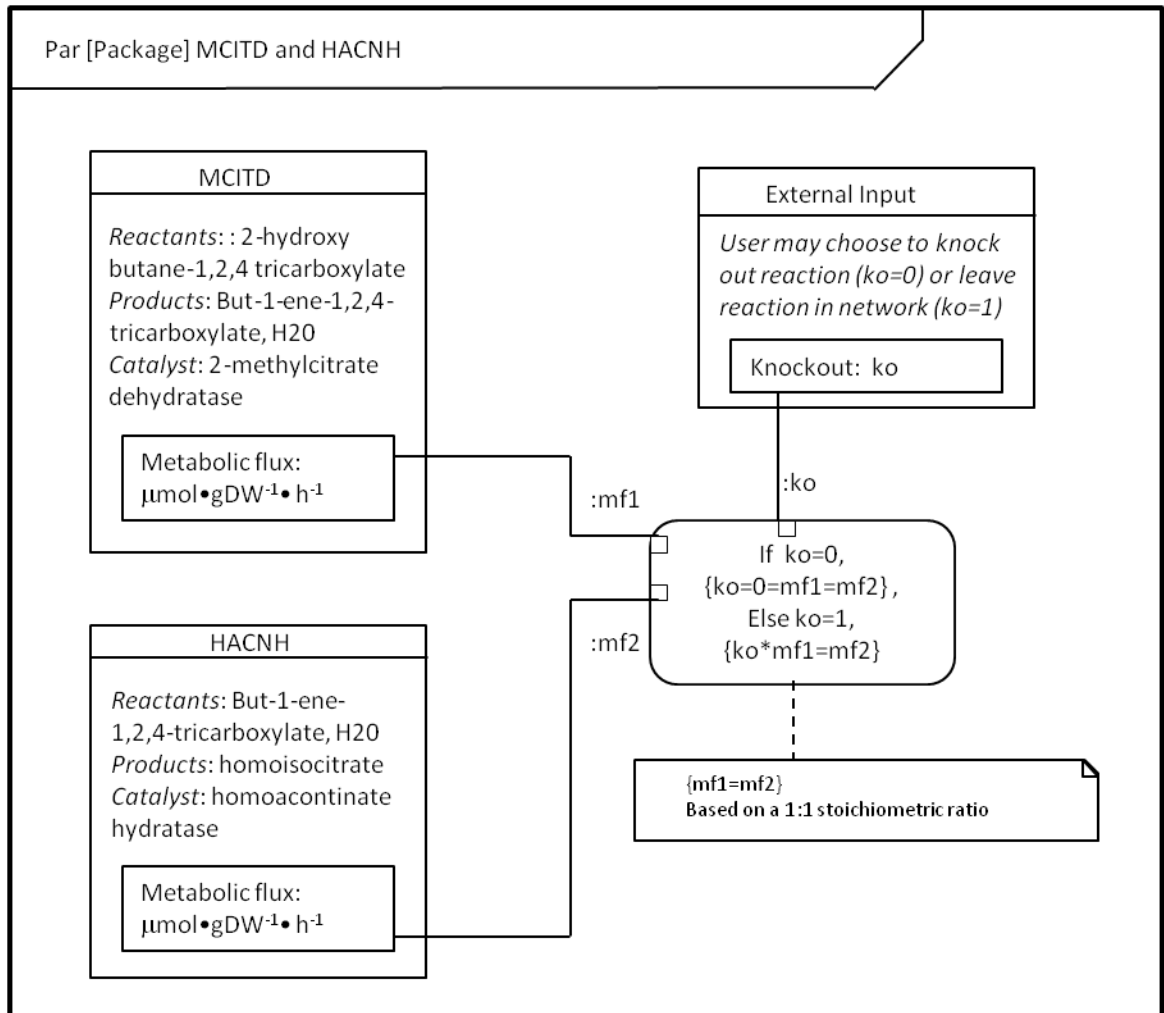

Figure 30 - Parametric Diagram defining parameters and constraints between MICITD and HACNH reactions

3.3.3 - SysML Abstraction

In this section, we briefly describe the key visual abstractions, and advantages and disadvantages of SysML as a visual formalism for supporting metabolic experiments.

Key Abstractions. SysML provides a wide range of diagram types for describing system structure, system behavior, requirements, and parametric relationships within a system.

SysML is deliberately designed to be application neutral. For metabolic engineering, the

most useful types of diagram are black boxes and block diagrams. See, for example, Figure 29 and Figure 30. The key abstractions for the SysML visualization are the black boxes and the block diagram. Black boxes have a one to one relationship with the subgraphs of SBGN, thereby encapsulating a series of reactions together, and hiding the details of each individual reaction. The block diagram represents a reaction, with the reactants, products, catalyst listed as attributes, with :mf at each port representing metabolic flux. It should be noted that the decision to use reactants, products, and enzymes as attributes was not mandated by the SysML specification, but a decision on our end to show how SysML could add an additional layer of abstraction over the SBGN models, resulting in a fewer number of total entities.

In order to show how SysML can model constraints and flows, we have also included a parametric diagram. For example, Figure 30 provides a detailed view of the constraints governing the MCITD and HACNH reactions. Using parametric diagrams we can set constraints based on the reaction stoichiometry (in this case 1:1), and experimental design (knockout indicates flux = 0). We were able to combine both constraints into one constraint using an if then statement and a block representing the external user. Since our purpose in creating the visualization prototype was only to make a point, we focused only on these two reactions. A more comprehensive example would attach constraints and parameters to every reaction in the network. The key point to note is that one can proceed through an entire pathway applying the rules and commands as set by the constraints, while outputting the associated parameters for tracking purposes. This capability would be an essential part of SysML becoming a central interface in a metabolic engineering design framework.

Advantages. As an established standard visual notation, SysML offers a lot of flexibility for the representation of metabolic networks. It has a formal methodology for representing flow, and it can show the topological connectivity of separate pathways. Looking ahead, BIOMEMS devices and systems are almost certain to become commonplace. Having a notation specific to machines also applied to biology may be useful for creating visual abstractions of machines interacting with living objects.

Disadvantages. The main disadvantage of SysML is its lack of support for biology-specific glyphs. To most straightforward compensation for this shortcoming is to write additional text (e.g., this is an enzyme) on the diagram. However, for all but the simplest systems, diagrams would quickly become cluttered, thereby obscuring a designer's ability to understand the network structure and behavior. We suggest that this limitation can be overcome by integrating SysML with SBGN or whatever graphical user interface (GUI) the researcher prefers.

3.4 - Systems Integration for Metabolic Engineering

In Section 2.4, we discussed the possibility of using SysML as a centerpiece integrator, designed to link the four quadrants of the multilevel framework shown in Figure 5 and Figure 6. This section will discuss how the metabolic engineering experiment fits into the systems engineering framework (see Figure 31) and offer perspective on how a metabolic engineering experiment could fit into the framework through the use of SysML wrappers.

Goals / Scenarios (Semi-Formal models)

The pathway from goals and scenarios to requirements can be documented with Use Case and Requirements Diagrams. Requirements leads to the generation of experimental

objectives and constraints. For example, our metabolic experiment has the standard functional requirement to maintain a living state in the yeast cell, and the performance requirement of maximizing artemisinin production in the yeast metabolism. We hypothesize that once the standard functional requirements have been correctly expressed in SysML, theoretically, a researcher could automate the validation and verification of the requirement for every result generated in the formal models. By automating the back-and-forth flow of data between the semi-formal and formal models, the time needed in order to determine the experimental feasibility of computational predictions will be reduced.

Visual Abstraction (Semi-Formal models)

As highlighted in Figure 21, there is a 1:1 relationship between many of the SBGN process diagram components and the components of a SysML internal block diagram. Recent research has shown that with XML representations for SysML and SBGN in place, it is certainly feasible to simultaneously display both types of diagrams, and synchronize user interface actions across the visualizations (Delgoshaei and Austin, 2011). While there are no standards for displaying color/size based flows, constraints and parameters can certainly propagate through the SysML wrapper in the internal code and give output values for metabolic flux. Metabolic flux values can also be included as annotations in SBGN, or whatever visual format is preferred by the end user. With respect to the *in silico* experiment, no single diagram type provides superior visual support for understanding how choking the lysine pathway redirected flux to the artemisinin producing pathways. Therefore, for the time being, this means that multiple forms of visualization are essential.

Semi-formal Models

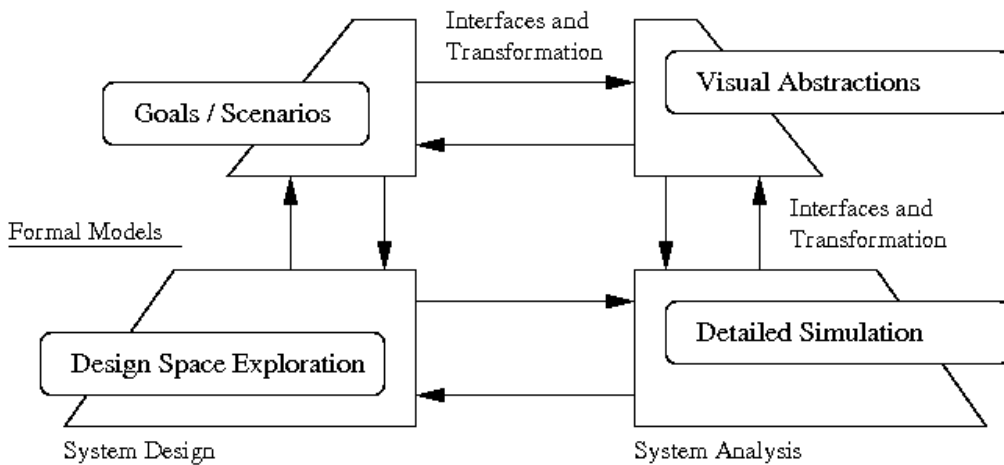

Goals / Scenarios → Requirements

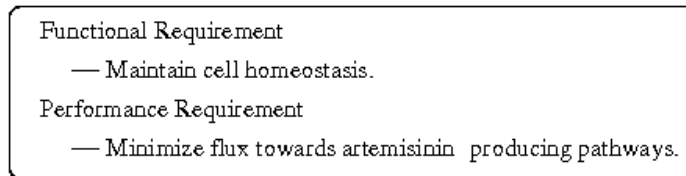

Visual Abstractions

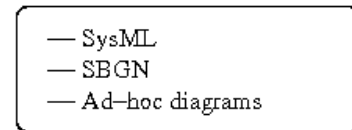

Detailed Simulation

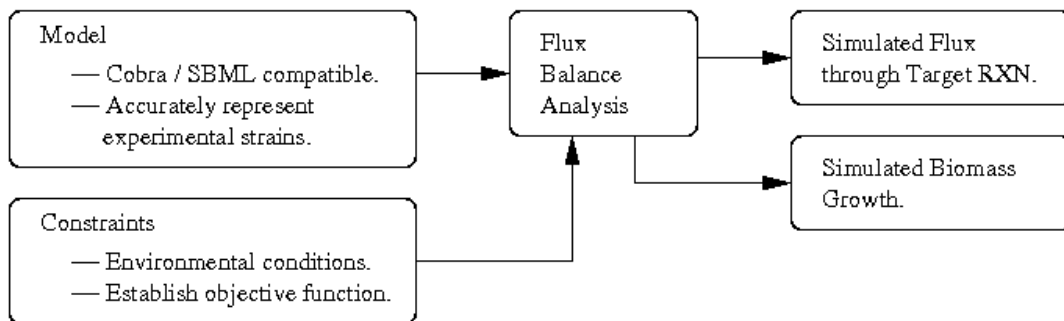

Design Space Exploration

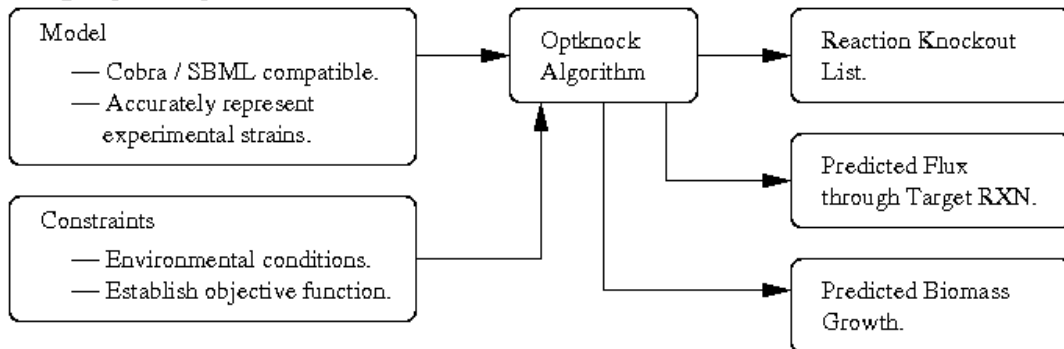

Figure 31 - Systems Integration - Plugging the *in silico* metabolic engineering experiment into the Systems Engineering framework

Design Space Exploration and Simulation (Formal models)

In the metabolic experiment both the design space exploration (OPTKNOCK) and simulation (FBA) were run using MATLAB and the COBRA Toolbox. Looking forward, we are not locked into this computational framework. There are, in fact, already interfaces on the market designed to wrap MATLAB code and scripts in a SysML interface (Bajaj et al, 2011). We note that because SysML provides support for flow-based modeling, flows of data to and from the wrapper will be possible. Together, these features can work together to give researchers options. A technically experienced researcher may prefer to run the experiment at the MATLAB layer. Less technically experienced researchers will be provided with a way to access the same experiment by interacting with the graphical SBGN layer.

Chapter 4 – Conclusion

4.1 - Summary

This paper has served two purposes: (1) We have proposed a multi-level framework for the synthesis, analysis and design of metabolic systems, and (2) We have applied this framework to a metabolic engineering experiment.

Design activities in the proposed framework are divided into four quadrants, and are based on formal models and semi-formal models for a network of linked system design and system analysis components. Goals and scenario analysis links semi-formal modeling to formal approaches to system design. Visual abstractions (e.g., SysML) are linked to formal approaches to system analysis. Design space exploration employs formal approaches to system design. Computer simulation employs formal approaches to system analysis.

Various aspects of this framework have been exercised by working step by step through an *in silico* metabolic engineering experiment. The results indicate that interruption of the pathway driving carbon from alpha-keto glutarate and acetyl CoA towards lysine would maximize flux through our target pathways, increasing artemisinin production. This makes sense because interruption of the lysine production pathway causes a buildup of acetyl CoA, which feeds into the mevalonate pathway, the insertion site of the genetically engineered pathways for artemisinin production. Our framework corresponds to the following aspects of the *in silico* experiment:

(1) Goals/scenarios involved maintaining a living state and maximizing production of the metabolite artemisinin;

(2) Visual abstraction involved ad hoc, SBGN, and SysML diagrams, which placed special emphasis on showing how reaction knockouts in the lysine pathway could redirect flux towards the artemisinin producing pathway;

(3) Design space exploration took the form of running a yeast model through the OPTKNOCK algorithm; and

(4) Computer simulation took the form of flux balance analysis.

4.2 - Future Work

Biological systems are now considered to be the Holy Grail of systems complexity. This study has been a first step. Although the scope of this study has been restricted to single-celled organisms in the form of yeast, these systems are still complex systems, with massive numbers of components which interact in a combinatorial fashion. As we work with higher-level organisms, increase our technological capabilities, and learn more about biology, both observational complexity and system design complexity will increase. It is evident that without new approaches to design space exploration and metabolic systems simulation, this will result in a large gap between design and validation capabilities and what is required from a productivity standpoint.

The software and systems engineering community has handled increasingly complex systems by developing the ability to solve problems at higher levels of abstraction. This strategy offers a pathway forward for the biological world to emulate. As of 2011, SysML is the benchmark visual modeling language for the field of systems engineering, and has been used as both a visual abstraction and interface for various portions of complex systems engineering projects.

Looking ahead, our proposed multilevel framework needs to take advantage of SysML, as a visual abstraction, as a construct for module wrapping, and as a mechanism for creating heterogeneous design environments composed from mixtures of formal and semi-formal models.

Appendices

Appendix A – MATLAB code

This is the MATLAB Code corresponding to the Schematic found in Figure 24 It loads an Excel Model of a Yeast Strain, modifies the model to represent the parameters and constraints of a simulated lab experiment, and outputs OPTKNOCK's Suggested Reaction Knockouts, OPTKNOCK's Flux Predictions with respect to biomass and the target reaction, PreKO FBA Simulation Results with respect to biomass and the target reaction, and PostKO FBA Simulation Results with respect to biomass and the target reaction.

```
%% OPTKNOCK / FBA Scripts for the Production of Artemisinin
%%
clear all
clc
%% Initiate Cobra Toolbox
initCobraToolbox;

%% Load Model (>>Use Modified Strain Model in Excel Format Here<<)
model = xls2model('imm904v51_120.xls','metimm904v51_120.xls');

%% change media to Synthetic Defined Dropout Media
% refer to excel file

% Carbon Source
model = changeRxnBounds(model,'EX_glc(e)',0,'b'); %glucose
model = changeRxnBounds(model,'EX_gal(e)',-11.1,'l'); %galactose
% Aerobic Growth
model = changeRxnBounds(model,'EX_o2(e)',-66.6,'l'); % oxygen uptake
% 6*carbon flux (i.e. maximum feasible flux as opposed to arbitrarily
large
% flux...see Feist et al 2010.

% Amino Acids/Bases

model = changeRxnBounds(model,'EX_ade(e)',-0.01087,'l'); %adenine
model = changeRxnBounds(model,'EX_ura(e)',0,'l'); %uracil (*DO)

model = changeRxnBounds(model,'EX_trp-L(e)',-0.009803,'l'); %Tryptophan
model = changeRxnBounds(model,'EX_his-L(e)',0,'l'); % histidine (*DO)
model = changeRxnBounds(model,'EX_nh4(e)',0,'l'); %Arginine (Gene KO
can1-100) (strain CY4)
model = changeRxnBounds(model,'EX_met-L(e)',-0.0134,'l'); %Methionine
model = changeRxnBounds(model,'EX_tyr-L(e)',-0.0165,'l'); % Tyrosine
model = changeRxnBounds(model,'EX_leu-L(e)',0,'l'); % leucine (*DO)
model = changeRxnBounds(model,'EX_ile-L(e)',-0.0229,'l'); %isoleucine
model = changeRxnBounds(model,'EX_lys-L(e)',-0.0163,'l'); %lysine
model = changeRxnBounds(model,'EX_phe-L(e)',-0.0303,'l');
%phenylalanine
model = changeRxnBounds(model,'EX_glu-L(e)',-0.0676,'l'); %glutamate
model = changeRxnBounds(model,'EX_asp-L(e)',-0.0746,'l'); %aspartic
acid
```

```

model = changeRxnBounds(model, 'EX_val-L(e)', -0.128, 'l'); %valine
model = changeRxnBounds(model, 'EX_thr-L(e)', -0.168, 'l'); %threonine
model = changeRxnBounds(model, 'EX_ser-L(e)', -0.381, 'l'); %serine

% Compounds
model = changeRxnBounds(model, 'EX_nh4(e)', -7.58, 'l'); %ammonium
model = changeRxnBounds(model, 'EX_so4(e)', -4.22, 'l'); %sulfate
model = changeRxnBounds(model, 'EX_k(e)', -0.797, 'l'); %potassium
model = changeRxnBounds(model, 'EX_pi(e)', -0.711, 'l'); %phosphate
model = changeRxnBounds(model, 'EX_btn(e)', -8.2*10^-6, 'l'); %biotin
model = changeRxnBounds(model, 'EX_inost(e)', -0.00556, 'l'); %inositol
model = changeRxnBounds(model, 'EX_4abz(e)', -0.000146, 'l'); %4-
aminobenzoic acid
model = changeRxnBounds(model, 'EX_thm(e)', -0.000133, 'l'); %thiamin
model = changeRxnBounds(model, 'EX_fe2(e)', -0.000123, 'l'); % Iron
(assuming fe3=fe2)
model = changeRxnBounds(model, 'EX_na1(e)', -0.1711, 'l'); % Sodium Ions
model = changeRxnBounds(model, 'ATPM', 1, 'b'); % ATP Maintenance

%% Remove some reactions from consideration

ind = 1:length(model.rxns);
last = find(ind, 1, 'last');

SpecRxnsRemove = {'biomass_SC5_notrace', 'ATPM', 'GRTT'}; %add ARTACID
for strain 2 and DARTACID for strain 3

clear TargRxnId TargInInd
for i=1:length(SpecRxnsRemove)
    rxn = SpecRxnsRemove{i};
    TargRxnId = find(strcmp(rxn, model.rxns));
    TargInInd = find(ind==TargRxnId);
    ind(TargInInd) = 0;
end

%% find reactions with no genes (Feist optknock step c)

clear TargRxnId TargInInd
for i=1:length(model.grRules)
    k(i) = strcmp(model.grRules(i), '');
    if k(i) == 1
        k2(i) = 1;
    else
        k2(i) = 0;
    end
end

Nogenes_ind = find(k2);
clear k
for i = 1:length(Nogenes_ind)
    TargRxnId = Nogenes_ind(i);
    TargInInd = find(ind==TargRxnId);
    ind(TargInInd) = 0;
end

```

```

end

%% find Exchange rxns %% Redundant (no genes associated with EX rxns)
% reactions)
% k = strfind(model.rxns,'EX_');
% clear TargRxnId TargInInd
% for i=1:length(k)
%     if k{i} == 1
%         k2(i) = 1;
%     else
%         k2(i) = 0;
%     end
% end
%
% Ex_ind = find(k2);
% clear k
% for i = 1:length(Ex_ind)
%     TargRxnId = Ex_ind(i);
%     TargInInd = find(ind==TargRxnId);
%     ind(TargInInd) = 0;
% end

%% find Transport Rxns
clear TargRxnId TargInInd
Trans = strfind(model.subSystems,'Transport');

for i=1:length(Trans)
    if Trans{i} == 1
        k2(i) = 1;
    else
        k2(i) = 0;
    end
end

Trans_ind = find(k2);
clear k
for i = 1:length(Trans_ind)
    TargRxnId = Trans_ind(i);
    TargInInd = find(ind==TargRxnId);
    ind(TargInInd) = 0;
end

%% Find other subsystems that are difficult to modify (Feist Optknock
step d2)

% Use Find transport rxn script

%% Find high carbon molecules, with 7 or more carbons (Feist optknock
step E)

% no code yet, here's an idea
% Search metabolite formulas with strcmp for c7 c8 c9 c10 c11 c12
% store met name
% searche rxns for rxns involving met name (maybe use model.S)
% store index of rxns

```



```

%% find rxns with zero flux (Remove dead-ends feist optknock step a1)
Sol = optimizeCbModel(model);
zeroflux_ind = find(Sol.x==0);
for i = 1:length(zeroflux_ind)
    ind(zeroflux_ind(i)) = 0;
end

ind = find(ind);

%% Find reactions corresponding to lethal gene deletion (feist opknock
step b)

% Lethal gene deletion is deletion growth rate less than 5% of preKO
GR.
% No script yet

%% Remove all reactions found
selectedRxns={model.rxns{ind}}; % ignore bracket error here, needs to
be {ind}

%% Constrain reactions for Optknock

constrOptInputs = {

% Biomass
'biomass_SC5_notrace',0.01,'G';

% Carbon Source
'EX_glc(e)',0,'E'; %glucose
'EX_gal(e)',-11.1,'G'; %galactose %

% Aerobic Growth
'EX_o2(e)',-66.6,'G'; % oxygen uptake %
% 6*carbon flux (i.e. maximum feasible flux as opposed to arbitrarily
large
% flux...see Feist et al 2010.

% Amino Acids/Bases

'EX_ade(e)',-0.01087,'G'; %adenine %
'EX_ura(e)',0,'G'; %uracil (*DO)

'EX_trp-L(e)',-0.009803,'G'; %Tryptophan %
'EX_his-L(e)',0,'G'; % histidine (*DO)
'EX_nh4(e)',0,'G'; %Arginine (Gene KO can1-100) (strain CY4)
'EX_met-L(e)',-0.0134,'G'; %Methionine
'EX_tyr-L(e)',-0.0165,'G'; % Tyrosine
'EX_leu-L(e)',0,'G'; % leucine (*DO)
'EX_ile-L(e)',-0.0229,'G'; %isoleucine
'EX_lys-L(e)',-0.0163,'G'; %lysine
'EX_phe-L(e)',-0.0303,'G'; %phenylalanine
'EX_glu-L(e)',-0.0676,'G'; %glutamate

```

```

'EX_asp-L(e)',-0.0746,'G'; %aspartic acid
'EX_val-L(e)',-0.128,'G'; %valine
'EX_thr-L(e)',-0.168,'G'; %threonine
'EX_ser-L(e)',-0.381,'G'; %serine
% Compounds
'EX_nh4(e)',-7.58,'G'; %ammonium
'EX_so4(e)',-4.22,'G'; %sulfate
'EX_k(e)',-0.797,'G'; %potassium
'EX_pi(e)',-0.711,'G'; %phosphate
'EX_btn(e)',-8.2*10^-6,'G'; %biotin
'EX_inost(e)',-0.00556,'G'; %inositol
'EX_4abz(e)',-0.000146,'G'; %4-aminobenzoic acid
'EX_thm(e)',-0.000133,'G'; %thiamin
'EX_fe2(e)',-0.000123,'G'; % Iron (assuming fe3fe2)
'EX_na1(e)',-0.1711,'G'; % Sodium Ions
'ATPM',1,'E'; % ATP Maintenance

% please note that GRTT is NOT part of the media but a rxn constraint
'GRTT',.1,'G'; % GRTT min (added 7-23)
};

%Must set at least two rxns here because optKnock is poorly written
for i = 1:length(constrOptInputs)
constrOpt.rxnList{i}=constrOptInputs{i,1};
constrOpt.values(i)=constrOptInputs{i,2};
constrOpt.sense(i)= constrOptInputs{i,3}; %G = greater %E is equal to;
L is for less than
end

%% Options for optKnock (>>SET TARGET RXN and Number of KOs here<<<)
options.targetRxn = 'GRTT';
options.vMax=120; %Set bound to feasible value instead of 'arbitrarily
large' i.e. 1000, 80 is 6*the carbon-6 source flux in case all flux
goes through 1 carbon compounds (feist optknock step a2)
options.numDel =2;
options.numDelSense = 'L';

%% Solve OptKnock
disp('OptKnock Starts')
optKnockSol = OptKnock(model, selectedRxn, options, constrOpt, [],
'true');
disp(['Optknock objective = ' num2str(optKnockSol.obj)])
disp(['OptKnock Growth rate = ' num2str(optKnockSol.fluxes(1))])

%% Pre KO FBA
tol = 1e-7;
premodelKO = model;
targetRxn=options.targetRxn;
preKOsol = optimizeCbModel(model);
pregrowthRate = preKOsol.f;
disp(['preKO growth rate = ' num2str(preKOsol.f)])
targrxnind = find(strcmp(model.rxn, options.targetRxn));
disp(['preKO target rxn flux = ' num2str(preKOsol.x(targrxnind))]);

if (preKOsol.stat == 1)
    % Max & min production of the metabolite at the optimal growth rate

```

```

    grRounded = floor(preKOsol.f/tol)*tol;
    premodelKO =
changeRxnBounds (premodelKO,premodelKO.rxns (premodelKO.c==1),grRounded, '
1');
    premodelKO = changeObjective (premodelKO,targetRxn);
    presolMax = optimizeCbModel (premodelKO, 'max');
    presolMin = optimizeCbModel (premodelKO, 'min');
    premaxProd = presolMax.f;
    preminProd = presolMin.f;
else
    premaxProd = 0;
    preminProd = 0;
end

%% Test optKnock Solution
%b stands for both lower and upper bound

tol = 1e-7;
deletions = optKnockSol.rxnList;
nDel = length(deletions);
modelKO = model;
targetRxn=options.targetRxn;
for i = 1:nDel
    modelKO = changeRxnBounds (modelKO,deletions{i},0, 'b');
end
% Calculate optimal growth rate
postKOsol = optimizeCbModel (modelKO);
growthRate = postKOsol.f;

if (postKOsol.stat == 1)
    % Max & min production of the metabolite at the optimal growth rate
    grRounded = floor(postKOsol.f/tol)*tol;
    modelKO =
changeRxnBounds (modelKO,modelKO.rxns (modelKO.c==1),grRounded, '1');
    modelKO = changeObjective (modelKO,targetRxn);
    solMax = optimizeCbModel (modelKO, 'max');
    solMin = optimizeCbModel (modelKO, 'min');
    maxProd = solMax.f;
    minProd = solMin.f;
else
    maxProd = 0;
    minProd = 0;
end

disp(['postKO growth rate = ' num2str(postKOsol.f)])
targrxnind = find(strcmp(model.rxns,options.targetRxn));
disp(['postKO target rxn flux FBA = '
num2str(postKOsol.x(targrxnind))]);
disp(['preKO solmax target rxn flux = ' num2str(premaxProd)]);
disp(['preKO solmin target rxn flux = ' num2str(preminProd)]);
disp(['postKO solmax target rxn flux = ' num2str(maxProd)]);
disp(['postKO solmin target rxn flux = ' num2str(minProd)]);

%% Script Written by Joseph Johnnie, Matt Conway, and Ashish Misra

```

References

1. Acton, N., & Roth, R. J. (1992). On the conversion of dihydroartemisinic acid into artemisinin. *The Journal of Organic Chemistry*, 57(13), 3610-3614.
2. Agrawala, M., Li, W., & Berthouzoz, F. (2011). Design principles for visual communication. *Communications of the ACM*, 54(4), 60.
3. Aregawi, M., & World Health Organization. (2010). *World malaria report 2010*. Geneva: World Health Organization.
4. Arsham, Hossein. (2011). *Deterministic Modeling: Linear Optimization with Applications*. Retrieved November 16, 2011, from <http://home.ubalt.edu/ntsbarsh/opre640a/partVIII.htm#rplp>
5. Athanasiou, Kyriacos & Ka-Yiu San. (2003). *Metabolic Flux Analysis*. Retrieved February 22, 2011, from <http://www.ruf.rice.edu/~bioewhit/courses/bioe321>
6. Austin, M. (2011). *Information-Centric Systems Engineering*, Class Notes for ENSE 621 System Concepts, Processes and Issues, Institute for Systems Research, University of Maryland, College Park, MD 20742, September 2011.
7. Bajaj, M., Zwemer, D., Peak, R., Phung, A., Scott, A., & Wilson, M. (2011). Satellites to Supply chains, Energy to Finance - SLIM for Model-Based Systems Engineering. *INCOSE International Symposium*.
8. Becker, S. A., Feist, A. M., Mo, M. L., Hannum, G., Palsson, B. Ø., & Herrgard, M. J. (2007). Quantitative prediction of cellular metabolism with constraint-based models: the COBRA Toolbox. *Nature Protocols*, 2(3), 727-738.
9. Bernhard O. Palsson. (2006). *Systems Biology: Properties of Reconstructed Networks* (1st ed.). New York: Cambridge University Press.

10. Boyle, N. R., & Morgan, J. A. (2011). Computation of metabolic fluxes and efficiencies for biological carbon dioxide fixation. *Metabolic Engineering*, 13(2), 150-158.
11. Burgard, A. P., Pharkya, P., & Maranas, C. D. (2003). OPTKNOCK: a bilevel programming framework for identifying gene knockout strategies for microbial strain optimization. *Biotechnology and Bioengineering*, 84(6), 647-657.
12. Covello, P. S., Teoh, K. H., Polichuk, D. R., Reed, D. W., & Nowak, G. (2007). Functional genomics and the biosynthesis of artemisinin. *Phytochemistry*, 68(14), 1864-1871.
13. Czauderna, T., Klukas, C., & Schreiber, F. (2010). Editing, validating and translating of SBGN maps. *Bioinformatics*, 26, 2340-2341.
14. Delgoshaei P. and Austin M.A., Software Design Patterns for Ontology-Enabled Traceability. Ninth Annual Conference on Systems Engineering Research (CSER 2011), Redondo Beach, CA, April 14-16, 2011.
15. Endy, D. (2005). Foundations for engineering biology. *Nature*, 438(7067), 449-453.
16. Feist, A. M., Zielinski, D. C., Orth, J. D., Schellenberger, J., Herrgard, M. J., & Palsson, B. Ø. (2010). Model-driven evaluation of the production potential for growth-coupled products of Escherichia coli. *Metabolic Engineering*, 12, 173-186.
17. Friedenthal, S. (2009). *A practical guide to SysML: the systems modeling language* ([Neuauf.]). Amsterdam [u.a.]: Elsevier Morgan Kaufmann OMG.

18. Gregory N. Stephanopoulos, Nielsen, Jens, & Aristidou, Aristos. (1998). *Metabolic Engineering: Principles and Methodologies* (1st ed.). San Diego: Academic Press.
19. Herrgård, M. J., Swainston, N., Dobson, P., Dunn, W. B., Arga, K. Y., Arvas, M., Büthgen, N., et al. (2008). A consensus yeast metabolic network reconstruction obtained from a community approach to systems biology. *Nature Biotechnology*, 26(10), 1155-1160.
20. Hucka, M., Finney, A., Sauro, H. M., Bolouri, H., Doyle, J. C., Kitano, H., and the rest of the SBML Forum:, et al. (2003). The systems biology markup language (SBML): a medium for representation and exchange of biochemical network models. *Bioinformatics*, 19(4), 524-531.
21. Hyduke, D., Hyduke, D., Schellenberger, J., Que, R., Fleming, R., Thiele, I., Orth, J., et al. (2011). COBRA Toolbox 2.0. *Protocol Exchange*.
22. Junker, B. H., Klukas, C., & Schreiber, F. (2006). VANTED: a system for advanced data analysis and visualization in the context of biological networks. *BMC Bioinformatics*, 7, 109.
23. Kim, J., & Reed, J. L. (2010). OptORF: Optimal metabolic and regulatory perturbations for metabolic engineering of microbial strains. *BMC Systems Biology*, 4, 53.
24. Lun, D. S., Rockwell, G., Guido, N. J., Baym, M., Kelner, J. A., Berger, B., Galagan, J. E., et al. (2009). Large-scale identification of genetic design strategies using local search. *Molecular Systems Biology*, 5.

25. Mo, M. L., Palsson, B. Ø., & Herrgård, M. J. (2009). Connecting extracellular metabolomic measurements to intracellular flux states in yeast. *BMC Systems Biology*, 3(1), 37.
26. Moodie, S., Moodie, S., Le Novere, N., Demir, E., Mi, H., & Villeger, A. (2011). Systems Biology Graphical Notation: Process Description language Level 1. *Nature Precedings*.
27. Mortimer, R. K., & Johnston, J. R. (1986). Genealogy of principal strains of the yeast genetic stock center. *Genetics*, 113(1), 35-43.
28. Le Novère N, Hucka M, Mi H, Moodie S, Schreiber F, Sorokin A, Demir E, Wegner K, Aladjem MI, Wimalaratne SM, Bergman FT, Gauges R, Ghazal P, Kawaji H, Li L, Matsuoka Y, Villéger A, Boyd SE, Calzone L, Courtot M, Dogrusoz U, Freeman TC, Funahashi A, Ghosh S, Jouraku A, Kim S, Kolpakov F, Luna A, Sahle S, Schmidt E, Watterson S, Wu G, Goryanin I, Kell DB, Sander C, Sauro H, Snoep JL, Kohn K, Kitano H. The Systems Biology Graphical Notation. *Nat Biotechnol*. 2009.
29. OMG: Systems Modeling Language v 1.2 (2010)
<http://www.omgsysml.org/#Specification>
30. Orth, J. D., Thiele, I., & Palsson, B. Ø. (2010). What is flux balance analysis? *Nature Biotechnology*, 28(3), 245-248.
31. Ro, D.-K., Paradise, E. M., Ouellet, M., Fisher, K. J., Newman, K. L., Ndungu, J. M., Ho, K. A., et al. (2006). Production of the antimalarial drug precursor artemisinic acid in engineered yeast. *Nature*, 440(7086), 940-943.

32. Sangiovanni-Vincentelli A., McGeer P.C., Saldanha A., Verification of Electronic Systems : A Tutorial, *Proceedings of the 33rd Design Automation Conference*, Las Vegas, 1996.
33. Schellenberger, J., Park, J. O., Conrad, T. M., & Palsson, B. Ø. (2010). BiGG: a Biochemical Genetic and Genomic knowledgebase of large scale metabolic reconstructions. *BMC Bioinformatics*, *11*(1), 213.
34. Thomas, B. J., & Rothstein, R. (1989). The genetic control of direct-repeat recombination in *Saccharomyces*: the effect of *rad52* and *rad1* on mitotic recombination at *GAL10*, a transcriptionally regulated gene. *Genetics*, *123*(4), 725-738.
35. Tomlin, C. J. (2005). Understanding biology by reverse engineering the control. *Proceedings of the National Academy of Sciences*, *102*, 4219-4220.
doi:10.1073/pnas.0500276102
36. Tomlin, Claire J., & Axelrod, J. D. (2007). Biology by numbers: mathematical modelling in developmental biology. *Nature Reviews Genetics*, *8*, 331-340.
doi:10.1038/nrg2098
37. Yang, L., Cluett, W. R., & Mahadevan, R. (2011). EMILiO: a fast algorithm for genome-scale strain design. *Metabolic Engineering*, *13*(3), 272-281.
38. Zhang, Y., Teoh, K. H., Reed, D. W., Maes, L., Goossens, A., Olson, D. J. H., Ross, A. R. S., et al. (2008). The molecular cloning of artemisinic aldehyde Delta11(13) reductase and its role in glandular trichome-dependent biosynthesis of artemisinin in *Artemisia annua*. *The Journal of Biological Chemistry*, *283*(31), 21501-21508.

